

**GRANDVIEW CITY COUNCIL
REGULAR MEETING AGENDA
TUESDAY, MARCH 10, 2026**



PLEASE NOTE: The maximum occupancy of the Council Chambers is 49 individuals at one time. Access to exits must be kept clear to ensure everyone in the Chambers can safely exit in the event of an emergency.

This meeting will be held in person and will also be available via teleconference.

REGULAR MEETING – 7:00 PM

PAGE

- 1. CALL TO ORDER & ROLL CALL**
- 2. PLEDGE OF ALLEGIANCE** – Jeremiah Ayala, 4th grade student at Smith Elementary
- 3. APPROVE AGENDA**
- 4. PRESENTATIONS**
- 5. PUBLIC COMMENT** – *The public may address the Council on any topic whether on the agenda or not, except those scheduled for public hearing. The public comment period is not an opportunity for dialogue with the Mayor and Councilmembers, or for posing questions with the expectation of an immediate answer. Many questions require an opportunity for information gathering and deliberation. For this reason, Council will accept comments, but will not directly respond to comments, questions or concerns during public comment. If you would like to address the Council, please step up to the microphone and give your name and address for the record. Your comments will be limited to three minutes.*
- 6. CONSENT AGENDA** – *Items on the Consent Agenda will be voted on together by the Council, unless a Councilmember requests that items be removed from the Consent Agenda and discussed and voted upon separately. An item removed from the Consent Agenda will be placed under Unfinished and New Business.*
 - A. Minutes of the February 10, 2026 Committee-of-the-Whole meeting
 - B. Minutes of the February 10, 2026 Council meeting
 - C. Payroll Check Nos. 14763-14775 in the amount of \$112,933.64
 - D. Payroll Check Nos. 14776-14794 in the amount of \$21,656.98
 - E. Payroll Electronic Fund Transfers (EFT) Nos. 61820-61824 in the amount of \$103,187.58
 - F. Payroll Electronic Fund Transfers (EFT) Nos. 61831-61837 in the amount of \$118,251.18
 - G. Payroll Direct Deposit 02/01/2026-02/15/2026 in the amount of \$163,424.67
 - H. Payroll Direct Deposit 02/16/2026-02/28/2026 in the amount of \$184,850.08
 - I. Claim Check Nos. 132934-133101 in the amount of \$1,078,579.18
- 7. ACTIVE AGENDA** – *Items discussed at the 6:00 pm Committee-of-the-Whole meeting of an urgent or time sensitive nature may be added to the active agenda pursuant to City Council Procedures Manual Section 3.18(c).*
 - A. Ordinance No. 2026-03 amending the 2026 Annual Budget 13-14
 - B. Resolution No. 2026-14 authorizing the Mayor to sign a Recreational Use Permit by and between the City of Grandview and the Lower Valley Cal Ripken League 15-20

	<u>PAGE</u>
C. Resolution No. 2026-15 declaring certain City property from the Police Department as surplus and authorizing disposal by public auction, sale or trade (vehicle)	21
D. Resolution No. 2026-16 declaring certain City property from the Police Department as surplus and authorizing disposal by public auction, sale, trade or disposal (computers)	22
E. Resolution No. 2026-17 amending Section 27.04(A) of the Credit Card Use Policy within the City of Grandview Personnel Policy Manual increasing credit card limits for the Police Chief and Assistant Police to \$10,000	23-25
F. Resolution No. 2026-18 accepting the fuel bid from Valley Wide Cooperative for the year beginning April 1, 2026 to March 31, 2027	26-33
G. Resolution No. 2026-19 accepting a request from Hugo Garibay for annexation of Parcel Nos. 230927-11424 and 230927-11425 located at 160 Hickory Road, Grandview, Yakima, County, Washington to the City of Grandview	34-37
8. UNFINISHED AND NEW BUSINESS	
9. CITY ADMINISTRATOR AND/OR STAFF REPORTS	
10. MAYOR & COUNCILMEMBER REPORTS	
11. ADJOURNMENT	

The City of Grandview Committee-of-the-Whole and Regular Council Meetings scheduled for Tuesday, March 10, 2026 at 6:00 pm and 7:00 pm will be held in person and will also be available via teleconference.

Please join the meeting from your computer, tablet or smartphone.

Join Zoom Meeting

<https://us06web.zoom.us/j/84214652389?pwd=ZikMVr11qx3rOxYmtb8Hr0ZxFfRama.1>

To join via phone: +1 253 215 8782

Meeting ID: 842 1465 2389

Passcode: 913544

**GRANDVIEW CITY COUNCIL
COMMITTEE-OF-THE-WHOLE MEETING MINUTES
FEBRUARY 10, 2026**

1. CALL TO ORDER

Mayor Ashley Lara called the Committee-of-the-Whole (C.O.W.) meeting to order at 6:00 p.m., in the Council Chambers at City Hall.

The meeting was held in person and was also available via teleconference.

2. ROLL CALL

Present in person: Councilmembers David Diaz, Ramona Garibay-Rios, Bill Moore (Mayor Pro Tem), Robert Ozuna and Joan Souders

Present via teleconference: None

Absent: Councilmembers Laura Flores and Javier Rodriguez

Staff present: City Administrator Shane Fisher, Assistant Police Chief Seth Bailey, Library Director Wendy Poteet and City Clerk Anita Palacios

3. NEW BUSINESS

A. Resolution authorizing the Mayor to sign an Addendum to the Interlocal Agreement between the City of Sunnyside and the City of Grandview for the Housing of Inmates

The City of Grandview and the City of Sunnyside enter into contracts for jail services. The contract was an Interlocal Agreement outlining the specifics regarding the treatment, costs and housing of inmates within Sunnyside jail. This agreement allows prisoners to be routinely housed in Sunnyside Jail. The yearly cost of housing was changed as needed through an addendum to the contract. The previously signed Interlocal Agreement with the City of Sunnyside remains the same. This Addendum represented an increase in per day rates from \$71.20 per day to \$78.91 per day.

Staff recommended the C.O.W. move a resolution authorizing the Mayor to sign an Addendum to the Interlocal Agreement between the City of Sunnyside and the City of Grandview for the Housing of Inmates to the February 10, 2026 regular Council meeting for consideration.

Discussion took place.

On motion by Councilmember Ozuna, second by Councilmember Souders, the C.O.W. moved a resolution authorizing the Mayor to sign an Addendum to the Interlocal Agreement between the City of Sunnyside and the City of Grandview for the Housing of Inmates to the February 10, 2026 regular Council meeting for consideration.

Vote:

- Councilmember Diaz – Yes
- Councilmember Flores – Absent
- Councilmember Garibay-Rios – Yes
- Councilmember Moore – Yes
- Councilmember Ozuna – Yes
- Councilmember Rodriguez – Absent
- Councilmember Souders – Yes

B. Resolution declaring firearms as surplus and authorizing the sale or trade of said firearms to a federally licensed firearm dealer

About every ten years Grandview Police Department sells/trades department issued officer handguns and replaces them. The Police Department currently has handguns issued to all officers and spare handguns to use if needed in the future. Staff recommended the following police issued handguns be declared as surplus property and be sold/traded to a federally licensed firearm dealer for new handguns:

Handgun & Serial Number

Heckler and Koch USP compact: 29-095854

Heckler and Koch USP45: 25-135593

Heckler and Koch USP45: 25-135596

Heckler and Koch USP45: 25-135612

Heckler and Koch USP45: 25-135604

Heckler and Koch USP45: 25-105413

Staff recommended the C.O.W. move a resolution declaring firearms as surplus and authorizing the sale or trade of said firearms to a federally licensed firearm dealer to the February 10, 2026 regular Council meeting for consideration.

Discussion took place.

On motion by Councilmember Garibay-Rios, second by Councilmember Moore, the C.O.W. moved a resolution declaring firearms as surplus and authorizing the sale or trade of said firearms to a federally licensed firearm dealer to the February 10, 2026 regular Council meeting for consideration.

Vote:

- Councilmember Diaz – Yes
- Councilmember Flores – Absent
- Councilmember Garibay-Rios – Yes
- Councilmember Moore – Yes
- Councilmember Ozuna – Yes
- Councilmember Rodriguez – Absent
- Councilmember Souders – Yes

C. Resolution declaring certain City property from the Police Department as surplus and authorizing disposal by public auction, sale or trade

The Police Department has the following vehicle which was no longer needed for the conduct of City business and was being recommended for surplus: 2020 Ford Explorer, VIN #1FM5K8AC4LGA55503 (vehicle was involved in an accident on November 21, 2025 and was declared a total loss by the insurance company)

Staff recommended the C.O.W. move a resolution declaring certain City property from the Police Department as surplus and authorizing disposal by public auction, sale or trade to the February 10, 2026 regular Council meeting for consideration.

Discussion took place.

On motion by Councilmember Moore, second by Councilmember Garibay-Rios, the C.O.W. moved a resolution declaring certain City property from the Police Department as surplus and authorizing disposal by public auction, sale or trade to the February 10, 2026 regular Council meeting for consideration.

Vote:

- Councilmember Diaz – Yes
- Councilmember Flores – Absent
- Councilmember Garibay-Rios – Yes
- Councilmember Moore – Yes
- Councilmember Ozuna – Yes
- Councilmember Rodriguez – Absent
- Councilmember Souders – Yes

D. Resolution authorizing the Mayor to sign a Partnership Agreement between LA County Library and the City of Grandview for One Book, One Coast Project

One Book, One Coast programs began in Seattle in 1998 and have since spread world-wide. In 2025, Seattle Public Libraries, Multnomah County Libraries, and LA County Libraries began discussing the feasibility of a “One Book, One Coast” program. After creating the framework, they began reaching out to other libraries in Washington, Oregon, and California to garner interest in the program, to which Grandview Library confirmed interest. For the inaugural event, the featured book would be *They Called Us Enemy* by George Takei. Friends of Grandview Library offered to purchase a set of 5-10 copies of this book so patrons could have the opportunity to read it before the program concluded on May 31, 2026. As part of this agreement, Grandview Library would provide free marketing materials and free access to stream the live author event with Mr. Takei on May 31, 2026. As part of this agreement, Grandview Library commits to hosting at least one (1) One Book, One Coast event between April 1 and May 31, 2026 and to promote the event as a whole through the Library’s print and digital marketing channels.

Staff recommended the C.O.W. move a resolution authorizing the Mayor to sign a Partnership

Agreement between LA County Library and the City of Grandview for One Book, One Coast Project to the February 10, 2026 regular Council meeting for consideration.

Discussion took place.

On motion by Councilmember Diaz, second by Councilmember Garibay-Rios, the C.O.W. moved a resolution authorizing the Mayor to sign a Partnership Agreement between LA County Library and the City of Grandview for One Book, One Coast Project to the February 10, 2026 regular Council meeting for consideration.

Vote:

- Councilmember Diaz – Yes
- Councilmember Flores – Absent
- Councilmember Garibay-Rios – Yes
- Councilmember Moore – Yes
- Councilmember Ozuna – Yes
- Councilmember Rodriguez – Absent
- Councilmember Souders – Yes

E. Resolution authorizing the Mayor to sign an Interlocal Agreement between Yakima County and the City of Grandview for Municipal Court Services

The City and Yakima County entered into a contract for Grandview Municipal Court Services on February 1, 2007. The contract has been renewed every five years. The last contract expired on December 31, 2025. Yakima County presented a new contract for Grandview Municipal Court Services effective January 31, 2026 through December 31, 2029.

Staff recommended the C.O.W. move a resolution authorizing the Mayor to sign an Interlocal Agreement between Yakima County and the City of Grandview for Municipal Court Services to the February 10, 2026 regular Council meeting for consideration.

Discussion took place.

On motion by Councilmember Moore, second by Councilmember Souders, the C.O.W. moved a resolution authorizing the Mayor to sign an Interlocal Agreement between Yakima County and the City of Grandview for Municipal Court Services to the February 10, 2026 regular Council meeting for consideration.

Vote:

- Councilmember Diaz – Yes
- Councilmember Flores – Absent
- Councilmember Garibay-Rios – Yes
- Councilmember Moore – Yes
- Councilmember Ozuna – Yes
- Councilmember Rodriguez – Absent

- Councilmember Souders – Yes

F. Ordinance amending the 2026 Annual Budget

Staff monitoring and review of fund and department budgets during the first month of 2026 identified numerous budget accounts to be amended. An ordinance was prepared to provide for the amending of the 2026 Annual Budget to accommodate the changes in sources and uses. By Fund the highlights of the budget changes were:

- **Current Expense Fund**: Increased estimated beginning fund balance. Increased revenues for DOJ COPS Grant, CJTC Grant – Officer Wellness and Contributions to Park. Increased appropriations for PD Patrol Insurance, Library Insurance, Parks Maintenance Insurance, Supplies to Fight Opioid Epidemic and Gym Equipment. Net effect was an increase in estimated ending fund balance.
- **American Rescue Plan Act Fund**: Increased estimated beginning fund balance. Increase revenues for City of Sunnyside Contribution. Increased appropriations for Pool Splash Pad and Grandview/Sunnyside Pathway. Net effect was no change in estimated ending fund balance.
- **Yakima Co. Law & Justice Tax Fund**: Increased estimated beginning fund balance with equal change in estimated ending fund balance.
- **Street Fund**: Increased estimated beginning fund balance. Increased revenues for FHWA Grant - WCR Sidewalk and Pathway. Increased appropriations for WCR Sidewalk and Pathway project. Net effect was an increase in estimated ending fund balance.
- **Transportation Benefit District Fund**: Increased estimated beginning fund balance. Increased appropriations for Elm Watermain Roadway Expansion and WCR Sidewalk and Pathway projects. Net effect was a decrease in estimated ending fund balance.
- **Cemetery Fund**: Increased estimated beginning fund balance. Increased appropriations for New Cemetery Engineering. Net effect was an increase in estimated ending fund balance.
- **SIED Loan – WCR/Higgins Fund**: Increased estimated beginning fund balance with equal change in estimated ending fund balance.
- **Capital Improvement Fund**: Reduction of estimated beginning fund balance. Increased revenues for Commerce Grant – New PD Building. Increase appropriations for New Police Department Building. Net effect was an increase in estimated ending fund balance.
- **E.M.S. Fund**: Increased estimated beginning fund balance. Increased appropriations for Ambulance Service. Net effect was an increase in estimated ending fund balance.
- **Water Fund**: Reduction of estimated beginning fund balance. Increased appropriations for New Well and decrease appropriations for New 3MG Reservoir. Net effect was a decrease in estimated ending fund balance.
- **Sewer Fund**: Reduction of estimated beginning fund balance. Increased revenues for DOE Loans – WWTP Improvements. Net effect was an increase in estimated ending fund balance.
- **Irrigation Fund**: Increased estimated beginning fund balance with equal change in estimated ending fund balance.
- **Solid Waste Fund**: Increased estimated beginning fund balance with equal change in estimated ending fund balance.

- **Equipment Rental Fund:** Increased estimated beginning fund balance with equal change in estimated ending fund balance.

Staff recommended the C.O.W. move an ordinance amending the 2026 Annual Budget to the February 24, 2026 regular Council meeting for consideration.

Discussion took place.

On motion by Councilmember Moore, second by Councilmember Garibay-Rios, the C.O.W. moved an ordinance amending the 2026 Annual Budget to the February 24, 2026 regular Council meeting for consideration.

Vote:

- Councilmember Diaz – Yes
- Councilmember Flores – Absent
- Councilmember Garibay-Rios – Yes
- Councilmember Moore – Yes
- Councilmember Ozuna – Yes
- Councilmember Rodriguez – Absent
- Councilmember Souders – Yes

5. CITY ADMINISTRATOR AND/OR STAFF REPORTS

2025 Council Retreat Summary – The 2025 Council Retreat Summary was received and distributed to Council for review. The summary would be included on a future Council agenda for discussion.

Splash Pad – An update on the splash pad was provided. The location of the splash pad was changed to Dykstra Park due to the availability of restroom facilities in proximity to the splash pad per Department of Health requirements. Staff met with the contractor and a permit application would be submitted to the Department of Health next week.

Safe Routes to School Application – A Safe Routes to School application was being considered for sidewalk improvements on West Second Street by the Middle School.

6. MAYOR & COUNCILMEMBER REPORTS

Public Safety Committee – The Public Safety Committee met with representatives from Congressman Newhouse and Senator Cantwell's offices on February 5th to discuss funding opportunities for the new Police Department. Senator Cantwell's direct congressional funding applications were due on March 8th. A meeting with Senator Murray's office was scheduled for February 26th at 2 p.m., to also discuss funding opportunities. The Committee also learned about a potential \$1.9 million funding opportunity through the Department of Commerce for pre-construction planning, with applications expected to open this spring.

Community Events – Mayor Lara provided an update on two upcoming community events: a May 30th evening hot air balloon rally called “Light Up the Valley – Grandview Balloon Rally” and a July 11th “Red, White and Balloon” event. These events would be in conjunction with the America’s 250 Celebration. She would begin community communication and volunteer recruitment for both events.

Flock Cameras – Positive feedback was noted on the Mayor’s recent Facebook post regarding immigration and the City’s stance on data sharing of Flock camera information.

7. ADJOURNMENT

On motion by Councilmember Moore, second by Councilmember Souders, the C.O.W. meeting adjourned 6:45 p.m.

Mayor Ashley Lara

Anita Palacios, City Clerk

**GRANDVIEW CITY COUNCIL
REGULAR MEETING MINUTES
FEBRUARY 10, 2026**

1. CALL TO ORDER

Mayor Ashley Lara called the regular meeting to order at 7:00 p.m. in the Council Chambers at City Hall.

The meeting was held in person and was also available via teleconference.

Present in person: Councilmembers David Diaz, Ramon Garibay-Rios, Bill Moore (Mayor Pro Tem), Robert Ozuna and Joan Souders

Present via teleconference: None

Absent: Councilmembers Laura Flores and Javier Rodriguez

On motion by Councilmember Moore, second by Councilmember Souders, Council excused Councilmembers Flores and Rodriguez from the meeting.

Vote:

- Councilmember Diaz – Yes
- Councilmember Flores – Absent
- Councilmember Garibay-Rios – Yes
- Councilmember Moore – Yes
- Councilmember Ozuna – Yes
- Councilmember Rodriguez – Absent
- Councilmember Souders – Yes

Staff present: City Administrator Shane Fisher, Library Director Wendy Poteet and City Clerk Anita Palacios

2. PLEDGE OF ALLEGIANCE

Lincoln Morales, 1st grade student at Thompson Elementary, led the pledge of allegiance.

3. APPROVE AGENDA

On motion by Councilmember Moore, second by Councilmember Ozuna, Council approved the February 10, 2026 meeting agenda as presented.

Vote:

- Councilmember Diaz – Yes
- Councilmember Flores – Absent
- Councilmember Garibay-Rios – Yes
- Councilmember Moore – Yes
- Councilmember Ozuna – Yes
- Councilmember Rodriguez – Absent
- Councilmember Souders – Yes

4. **PRESENTATIONS**

A. **2026 Proclamation – Grandview High School Career and Technical Education Month**

Mayor Lara proclaimed February 2026 as Career and Technical Education month in the City of Grandview and urged all citizens to become familiar with the services and benefits offered by the Career and Technical Education programs in this community and to support and participate in these programs to enhance their individual work skills and productivity.

5. **PUBLIC COMMENT** – None

6. **CONSENT AGENDA**

On motion by Councilmember Ozuna, second by Councilmember Souders, Council approved the Consent Agenda consisting of the following:

- A. **Minutes of the January 27, 2026 Committee-of-the-Whole meeting**
- B. **Minutes of the January 27, 2026 Council meeting**
- C. **Payroll Check Nos. 14743-14762 in the amount of \$23,706.71**
- D. **Payroll Electronic Fund Transfers (EFT) Nos. 17701-17707 in the amount of \$114,916.78**
- E. **Payroll Direct Deposit 01/16/2026-01/31/2025 in the amount \$175,954.10**
- F. **Claim Check Nos. 132834-132933 in the amount of \$1,040,587.91**

Vote:

- Councilmember Diaz – Yes
- Councilmember Flores – Absent
- Councilmember Garibay-Rios – Yes
- Councilmember Moore – Yes
- Councilmember Ozuna – Yes
- Councilmember Rodriguez – Absent
- Councilmember Souders – Yes

7. **ACTIVE AGENDA**

A. **Resolution No. 2026-09 authorizing the Mayor to sign an Addendum to the Interlocal Agreement between the City of Sunnyside and the City of Grandview for the Housing of Inmates**

This item was previously discussed at the February 10, 2026 C.O.W. meeting.

On motion by Councilmember Ozuna, second by Councilmember Garibay-Rios, Council approved Resolution No. 2026-09 authorizing the Mayor to sign an Addendum to the Interlocal Agreement between the City of Sunnyside and the City of Grandview for the Housing of Inmates.

Vote:

- Councilmember Diaz – Yes
- Councilmember Flores – Absent
- Councilmember Garibay-Rios – Yes
- Councilmember Moore – Yes
- Councilmember Ozuna – Yes
- Councilmember Rodriguez – Absent
- Councilmember Souders – Yes

B. Resolution No. 2026-10 declaring firearms as surplus and authorizing the sale or trade of said firearms to a federally licensed firearm dealer

This item was previously discussed at the February 10, 2026 C.O.W. meeting.

On motion by Councilmember Moore, second by Councilmember Diaz, Council approved Resolution No. 2026-10 declaring firearms as surplus and authorizing the sale or trade of said firearms to a federally licensed firearm dealer.

Vote:

- Councilmember Diaz – Yes
- Councilmember Flores – Absent
- Councilmember Garibay-Rios – Yes
- Councilmember Moore – Yes
- Councilmember Ozuna – Yes
- Councilmember Rodriguez – Absent
- Councilmember Souders – Yes

C. Resolution No. 2026-11 declaring certain City property from the Police Department as surplus and authorizing disposal by public auction, sale or trade

This item was previously discussed at the February 10, 2026 C.O.W. meeting.

On motion by Councilmember Diaz, second by Councilmember Ozuna, Council approved Resolution No. 2026-11 declaring certain City property from the Police Department as surplus and authorizing disposal by public auction, sale or trade.

Vote:

- Councilmember Diaz – Yes
- Councilmember Flores – Absent
- Councilmember Garibay-Rios – Yes
- Councilmember Moore – Yes
- Councilmember Ozuna – Yes
- Councilmember Rodriguez – Absent
- Councilmember Souders – Yes

D. Resolution No. 2026-12 authorizing the Mayor to sign a Partnership Agreement between LA County Library and the City of Grandview for One Book, One Coast Project

This item was previously discussed at the February 10, 2026 C.O.W. meeting.

On motion by Councilmember Garibay-Rios, second by Councilmember Moore, Council approved Resolution No. 2026-12 authorizing the Mayor to sign a Partnership Agreement between LA County Library and the City of Grandview for One Book, One Coast Project.

Vote:

- Councilmember Diaz – Yes
- Councilmember Flores – Absent
- Councilmember Garibay-Rios – Yes
- Councilmember Moore – Yes
- Councilmember Ozuna – Yes
- Councilmember Rodriguez – Absent
- Councilmember Souders – Yes

E. Resolution No. 2026-13 authorizing the Mayor to sign an Interlocal Agreement between Yakima County and the City of Grandview for Municipal Court Services

This item was previously discussed at the February 10, 2026 C.O.W. meeting.

On motion by Councilmember Moore, second by Councilmember Souders, Council approved Resolution No. 2026-13 authorizing the Mayor to sign an Interlocal Agreement between Yakima County and the City of Grandview for Municipal Court Services.

Vote:

- Councilmember Diaz – Yes
- Councilmember Flores – Absent
- Councilmember Garibay-Rios – Yes
- Councilmember Moore – Yes
- Councilmember Ozuna – Yes
- Councilmember Rodriguez – Absent
- Councilmember Souders – Yes

- 8. UNFINISHED AND NEW BUSINESS – None**
- 9. CITY ADMINISTRATOR AND/OR STAFF REPORTS – None**
- 10. MAYOR & COUNCILMEMBER REPORTS – None**

11. ADJOURNMENT

On motion by Councilmember Moore, second by Councilmember Souders, the Council meeting adjourned at 7:25 p.m.

Mayor Ashley Lara

Anita Palacios, City Clerk

ORDINANCE NO. 2026-03

**AN ORDINANCE OF THE CITY OF GRANDVIEW, WASHINGTON,
AMENDING THE 2026 ANNUAL BUDGET**

WHEREAS, the original 2026 estimated beginning fund balances and revenues do not reflect available budget sources; and

WHEREAS, there are necessary and desired changes in uses and expenditure levels in the funds; and

WHEREAS, there are sufficient sources within the funds to meet the anticipated expenditures.

NOW THEREFORE, THE CITY COUNCIL OF THE CITY OF GRANDVIEW, WASHINGTON DO ORDAIN AS FOLLOWS:

Section 1. That the 2026 annual budget be amended to reflect the changes presented in Exhibit A.

Section 2. That the City Administrator is authorized and directed to adjust estimated revenues, expenditures and fund balances reflecting the determined changes.

Section 3. This Ordinance shall be in full force and effect five (5) day after its passage and publication as required by law.

PASSED by the **CITY COUNCIL** and **APPROVED** by the **MAYOR** at its regular meeting on March 10, 2026.

MAYOR

ATTEST:

CITY CLERK

APPROVED AS TO FORM:

CITY ATTORNEY

PUBLICATION:
EFFECTIVE:

Exhibit A Continued

	Beginning Balance	Estimated Revenues	Appropriated Expenditures	Ending Balance	Budget Total
Capital Improvement Fund					
Original 2026 Budget	720,680	561,500	701,000	581,180	1,282,180
Amendment Amount	(41,000)	340,000	200,000	99,000	299,000
Amended Total	679,680	901,500	901,000	680,180	1,581,180
E.M.S. Fund					
Original 2026 Budget	328,180	670,100	626,100	372,180	998,280
Amendment Amount	53,000		35,500	17,500	53,000
Amended Total	381,180	670,100	661,600	389,680	1,051,280
Water Fund					
Original 2026 Budget	9,529,225	12,535,050	17,782,610	4,281,665	22,064,275
Amendment Amount	(336,000)		(300,000)	(36,000)	(336,000)
Amended Total	9,193,225	12,535,050	17,482,610	4,245,665	21,728,275
Sewer Fund					
Original 2026 Budget	12,176,980	6,652,650	12,136,020	6,693,610	18,829,630
Amendment Amount	(344,000)	430,000		86,000	86,000
Amended Total	11,832,980	7,082,650	12,136,020	6,779,610	18,915,630
Irrigation Fund					
Original 2026 Budget	53,410	720,750	738,300	35,860	774,160
Amendment Amount	17,000			17,000	17,000
Amended Total	70,410	720,750	738,300	52,860	791,160
Solid Waste Fund					
Original 2026 Budget	302,790	1,547,050	1,665,590	184,250	1,849,840
Amendment Amount	51,000			51,000	51,000
Amended Total	353,790	1,547,050	1,665,590	235,250	1,900,840
Equipment Rental Fund					
Original 2026 Budget	1,121,770	745,000	812,890	1,053,880	1,866,770
Amendment Amount	30,000			30,000	30,000
Amended Total	1,151,770	745,000	812,890	1,083,880	1,896,770

RESOLUTION NO. 2026-14

**A RESOLUTION OF THE CITY OF GRANDVIEW, WASHINGTON,
AUTHORIZING THE MAYOR TO SIGN A RECREATIONAL USE PERMIT
BY AND BETWEEN THE CITY OF GRANDVIEW AND THE
LOWER VALLEY CAL RIPKEN LEAGUE**

WHEREAS, the City of Grandview and the Lower Valley Cal Ripken League desire to enter into a Recreational Use Permit regarding the use of the Ralph Scott Memorial Ballfields at the Country Park Events Center;

NOW, THEREFORE, BE IT RESOLVED BY THE CITY COUNCIL OF THE CITY OF GRANDVIEW, WASHINGTON, as follows:

The Mayor is hereby authorized to sign a Recreational Use Permit by and between the City of Grandview and the Lower Valley Cal Ripken League in the form as is attached hereto and incorporated herein by reference.

PASSED by the **CITY COUNCIL** and **APPROVED** by the **MAYOR** at its regular meeting March 10, 2026.

MAYOR

ATTEST:

CITY CLERK

APPROVED AS TO FORM:

CITY ATTORNEY

RECREATIONAL USE PERMIT

By and Between City of Grandview and Lower Valley Cal Ripken League

This Agreement entered into this 10th day of March, 2026, by and between the City of Grandview, and Lower Valley Cal Ripken League for the uses and purposes stated herein and below.

1. Recitals

A. The City of Grandview, hereafter called the "City" is a municipal corporation of the State of Washington, with City Hall located at 207 W. 2nd Street, Grandview, WA 98930.

B. Lower Valley Cal Ripken League, hereafter called "Baseball League" is a non-profit organization with organized and stated purposes of organizing baseball competition between teams of the organization.

C. City owns Ralph Scott Memorial Ball Fields at the Country Park Events Center. Such facilities include baseball fields suitable for competition, hereafter called the "Baseball Facility".

D. City and Baseball League desire to enter into a Recreational Use Permit regarding the use of Baseball Facility.

2. Agreement

Wherefore, in consideration of mutual covenants, conditions and promises herein, the parties agree as follows:

Responsibilities of Baseball League:

A. Baseball League seeks to gain access for the use of Baseball Facility to conduct a program of baseball, in accordance with its own rules and regulations.

B. Baseball League shall pay the City a Recreational Use Permit fee of \$25 for each use of the ball field lights. An accurate account of each use of the ball field lights will be recorded by the league and submitted to the City at the end of the season for appropriate billing. The Recreational Use Permit authorizes Baseball League to use the Baseball Facility as mutually scheduled between March 10 and July 31, 2026. Baseball League acknowledges that City sponsored programs and community events have scheduling priority over Baseball League's use of the Baseball Facility under this Agreement, and that Baseball League may not use the Baseball Facility if such use conflicts with a City sponsored program or community event. Baseball League shall not use the Baseball Facility additionally without first obtaining further written permission from the City and the payment of additional fees as established by the City.

C. At no time shall Baseball League participants, coaches, officials, spectators, vendors, or any other people drive or park any vehicles on the Baseball Facility, except maintenance and emergency response vehicles. No vehicles shall be allowed on the field or the grass at the Country Park Events Center, except maintenance and emergency response vehicles. All vehicles must be parked in spaces designated for parking. Only individuals with a current Washington State Disabled Parking Permit will be allowed to park in designated disabled parking areas. All other vehicles associated with the Baseball League will park in the main parking lot at the Country Park Events Center.

D. Baseball League shall be solely and completely responsible for maintaining the dirt infields, facility fencing, dugout shelters, benches, storage units/areas and on-site equipment in a clean, neat and safe condition. The City will be responsible for mowing and trimming of grass, restroom maintenance and garbage dumpsters. Baseball League shall provide routine litter clean-up and shall properly dispose of all trash on or surrounding the Baseball Facility, including parking areas, during the period of time that Baseball League shall be using the Baseball Facility. Baseball League shall be responsible for any damage that occurs to the Baseball Facility as a result or incidental to, Baseball League's use of the Baseball Facility under this Agreement. It is the responsibility of the Baseball league to keep all participants and spectators out of the livestock building and amphitheater areas. Baseball League will be allowed to engage in off-season field and structure maintenance of the baseball facility as scheduled through the parks and recreation department.

E. Should Baseball League desire to make improvements and/or install equipment for use on the Baseball Facility, Baseball League shall seek prior written approval of the City before any equipment may be installed. Baseball League shall be solely responsible to ensure that said equipment meets the requirements of the U.S. Consumer Products Commission or other state or federal agency charged with the establishment of safety standards for such equipment. Upon installation of said equipment, such equipment shall remain the sole property of the City unless otherwise specifically agreed upon in writing by both parties.

F. Baseball League is aware of and will abide by all elements of the Grandview Municipal Code of Chapter 12.20 (Park Code).

G. Indemnification/Hold Harmless. User shall defend, indemnify and hold harmless the City of Grandview, its officers, officials, employees and volunteers from and against any and all claims, suits, actions, or liabilities for injury or death of any person, or for loss or damage to property, which arises out of the use of Premises or from any activity, work or thing done, permitted, or suffered by User in or about the Premises, except only such injury or damage as shall have been occasioned by the sole negligence of the City of Grandview.

H. Insurance Term. User shall procure and maintain for the duration of the use or rental period insurance against claims for injuries to persons or damage to property which may arise from or in connection with the use of the facilities and the activities of the User and his or her guests, representatives, volunteers and employees.

I. No Limitation. User's maintenance of insurance as required by the Agreement shall not be construed to limit the liability of the User to the coverage provided by such insurance, or otherwise limit the City of Grandview's recourse to any remedy available at law or in equity.

J. Required Insurance. User's required insurance shall be as follows: General Liability insurance shall be at least as broad as Insurance Services Office (ISO) occurrence form CG 00 01 covering premises, operations, products-completed operations and contractual liability. The City of Grandview shall be named as an additional insured on User's General Liability insurance policy using ISO Additional Insured-Managers or Lessors of Premises Form CG 20 11 or an endorsement providing at least as broad coverage. The General Liability insurance shall be written with limits no less than \$1,000,000 each occurrence, \$1,000,000 general aggregate. General Liability insurance shall also include coverage for participant liability with limits of not less than \$1,000,000 per occurrence. The insurance policy shall contain or be endorsed to contain that the User's insurance coverage shall be primary insurance as respect the City of Grandview. Any insurance, self-insurance, or self-insured pool coverage maintained by the City of Grandview shall be excess of the User's insurance and shall not contribute with it.

K. City of Grandview Full Availability of User Limits. If the User maintains higher insurance limits than the minimums shown above, the City of Grandview shall be insured for the full available limits of Commercial General and Excess or Umbrella liability maintained by the User, irrespective of whether such limits maintained by the User are greater than those required by this contract or whether any certificate of insurance furnished to the City of Grandview evidences limits of liability lower than those maintained by the User.

L. Certificate of Insurance and Acceptability of Insurers. The User shall provide a certificate of insurance evidencing the required insurance before using the Premises. Insurance is to be placed with insurers with a current A.M. Best rating of not less than A: VII.

M. Baseball League has inspected the Baseball Facility and the Country Park Events Center and any equipment located upon such facility, and finds such to be adequate for Baseball Leagues use. Baseball League and those individuals using such facilities and equipment through Baseball League and this Agreement do so at their own risk.

N. Under a separate Concession Agreement, the Baseball League shall be entitled to operate a concession stand upon site approved by the City. Baseball League shall comply with all applicable health code requirements, including but not limited to food preparation, storage, sanitation and waste removal. Baseball League shall be solely responsible for compliance with all applicable laws and regulations pertaining to sales tax and tax reporting.

O. Users of athletic fields and facilities for youth sports shall comply with the guidance of RCW 28A.600.190 and RCW 28A.600.195 regarding youth sports concussion, head injuries and sudden cardiac arrest.

P. Baseball League agrees to comply with RCW 49.60.500, made applicable to community athletic programs by RCW 35A.21.350, and prohibit discrimination on the basis of gender with respect to all activities undertaken in connection with this Agreement.

Q. Independent Contractors. The parties are independent contractors, and nothing in this Agreement shall be construed to create a partnership, joint venture or any other relationship than independent contractors. Baseball League shall be and remain in sole charge, supervision and control of all Baseball League activities, games, training and programs. City shall remain in sole charge, supervision and control of all its parks and recreation programs of the City of Grandview.

R. Term of Agreement. The term of this Agreement shall be for the term of the season set forth in Section B above. Notwithstanding termination of this Agreement through expiration of the term, the provisions relating to insurance and indemnification in Section H arising out of occurrences within the coverage of such insurance and/or use of Baseball League's equipment at any time, shall survive termination of this Agreement.

S. Termination. Either party may terminate this Agreement for any reason upon thirty (30) days written notice to the other. In the event Baseball League fails to abide by the terms and conditions of this Agreement or in the event of an Emergency, the City may terminate this Agreement upon such terms and at such time as the City deems necessary and appropriate, provided notice of termination for cause shall be provided to Baseball League. For purposes of this section, the term "Emergency" means any changes of the Comprehensive Plan or Parks & Recreation Plan mandated by governmental authorities and agencies with jurisdiction. Notwithstanding an early termination of this Agreement, the provisions relating to insurance and indemnification in Sections G and H arising out of occurrences within the coverage of such insurance and/or use of Baseball League's equipment at any time, shall survive termination of this Agreement.

T. Entire Agreement. This Agreement, with Baseball League's application for use of City's park facilities, constitutes the entire agreement of the parties, and shall not be amended except in writing signed by both parties. All terms and provisions of the City's application for use of park facilities shall apply to this Agreement and are incorporated herein by this reference. In the event of conflict between this Agreement and the terms and provisions of such application, the terms of this Agreement shall control.

U. Assignment. This Agreement and the terms and provisions herein are personal to Baseball League and shall not be assigned to any third party without the written authorization of the City, which approval shall not be unreasonably withheld.

Wherefore, this Agreement is deemed executed and effective on the date first referenced above.

City of Grandview

Baseball League

By: _____
Mayor Ashley Lara

By: 
Baseball League Coordinator

ATTEST:

By: _____
Anita Palacios, City Clerk

APPROVED AS TO FORM:

By: _____
City Attorney

RESOLUTION NO. 2026-15

**A RESOLUTION OF THE CITY OF GRANDVIEW, WASHINGTON,
DECLARING CERTAIN CITY PROPERTY FROM THE POLICE DEPARTMENT
AS SURPLUS AND AUTHORIZING DISPOSAL BY PUBLIC AUCTION,
SALE OR TRADE**

WHEREAS, the Police Department has a vehicle that have outlived its useful life and is no longer needed for the conduct of City business; and,

WHEREAS, the City Council has determined that it is in the best interest of the City that the foregoing vehicle be declared surplus and disposed of;

NOW THEREFORE, BE IT RESOLVED BY THE CITY COUNCIL OF THE CITY OF GRANDVIEW, as follows:

Section 1. The following vehicle is hereby declared to be surplus:

- 1992 Ford Armored Truck, VIN #1FDXK74P1NVA27075 (former SWAT vehicle)

Section 2. City staff is authorized to dispose of the vehicle described in section 1 of this resolution by public auction, sale or trade for an amount that represents a fair market value of the vehicle.

Section 3. The City Administrator is authorized to establish a minimum sale/trade-in price that reflects a fair market value of the vehicle described in section 1 of this resolution as deemed necessary to protect the City's interests.

PASSED by the **CITY COUNCIL** and **APPROVED** by the **MAYOR** at a special meeting on March 10, 2026.

MAYOR

ATTEST:

CITY CLERK

APPROVED AS TO FORM:

CITY ATTORNEY

RESOLUTION NO. 2026-16

**A RESOLUTION OF THE CITY OF GRANDVIEW, WASHINGTON,
DECLARING CERTAIN CITY PROPERTY FROM THE POLICE DEPARTMENT
AS SURPLUS AND AUTHORIZING DISPOSAL BY PUBLIC AUCTION,
SALE, TRADE OR DISPOSAL (COMPUTERS)**

WHEREAS, the City no longer has a need for certain personal property that has outlived its useful life and no longer needed for the conduct of City business; and,

WHEREAS, the City Council has determined that it is in the best interest of the City that the foregoing described equipment be declared surplus and disposed of;

NOW THEREFORE, BE IT RESOLVED BY THE CITY COUNCIL OF THE CITY OF GRANDVIEW, as follows:

Section 1. The following Police Department computers and/or laptops are hereby declared surplus and no longer needed for the conduct of City business:

<u>SERIAL #</u>	<u>BRAND</u>	<u>SERIAL #</u>	<u>BRAND</u>
696742	ALDEN	7146701	ALDEN
7146703	ALDEN	7262401	ALDEN
7262402	ALDEN	7296002	ALDEN
7357101	ALDEN	7357103	ALDEN
7418501	ALDEN	7418502	ALDEN
7418503	ALDEN	7458603	ALDEN
7528001	ALDEN	7528004	ALDEN
64400-02	ALDEN	72-96003	ALDEN
9KLXWB1	DELL	HF50KS1	DELL
MXL4402H6Y HP			

Section 2. City staff is authorized to dispose of the equipment described in Section 1 of this resolution by public auction, sale, trade-in or disposal for an amount that represents a fair market value of the equipment.

Section 3. The City Administrator is authorized to establish a minimum sale/trade-in price that reflects a fair market value of the equipment described in Section 1 of this resolution as deemed necessary to protect the City's interests.

PASSED by the **CITY COUNCIL** and **APPROVED** by the **MAYOR** at its regular meeting on March 10, 2026.

MAYOR

ATTEST:

CITY CLERK

APPROVED AS TO FORM:

CITY ATTORNEY

RESOLUTION NO. 2026-17

**A RESOLUTION OF THE CITY OF GRANDVIEW, WASHINGTON,
AMENDING SECTION 27.04 (A) OF THE CREDIT CARD USE POLICY
WITHIN THE CITY OF GRANDVIEW PERSONNEL POLICY MANUAL
INCREASING CREDIT CARD LIMITS FOR THE POLICE CHIEF,
ASSISTANT POLICE CHIEF TO \$10,000**

WHEREAS, the City Council of the City of Grandview adopted a new Credit Card Use Policy as Chapter 27 of the Grandview Personnel Policy Manual on April 8, 2014; and

WHEREAS, the City Council desires to make certain amendments to the Credit Card Use Policy,

NOW, THEREFORE, BE IT RESOLVED BY THE CITY COUNCIL OF THE CITY OF GRANDVIEW, WASHINGTON, as follows:

Section 1: Grandview Personnel Manual Section 27.04, Policy, which reads as follows:

27.04 Policy:

A. The City Council has authorized the City Administrator to implement procedures for the use of City credit cards for the following uses:

- Travel: Credit cards may be used by the above assigned individuals (section 2) for official business – related expenditures for hotel, parking, ferry, taxi, meals, gas, airline tickets, emergency city vehicle repairs and other travel related expenses as authorized by the Mayor or City Administrator. In addition,(a) the assigned individual may use the City credit card for conference and class registrations. Out of state travel and out of state registration require the Mayor's pre-approval.
- Purchases: The assigned credit cards may be used for ordering supplies, including on-line purchases, under \$1,000 for City purposes, when pre-approved by the Department Director. The City Clerk's credit card shall be utilized for on-line purchases over \$1,000 with pre-approval by the City Clerk and City Administrator.
- Purchases where an open charge account exists may be utilized for convenience at the time of purchase with the approval of the City Administrator.

- Credit Limit: The credit limit for each assigned City credit card shall be \$1,000 for employees. The City Administrator, Police Chief, Assistant Police Chief, Fire Chief and Public Works Director's credit limit for said assigned City credit card shall be \$5,000. The City Clerk's credit limit for said assigned City credit card shall be \$10,000.
- City credit cards shall NOT be used for cash advances or personal purchases.

is hereby amended to read as follows:

27.04 Policy:

A. The City Council has authorized the City Administrator to implement procedures for the use of City credit cards for the following uses:

- Travel: Credit cards may be used by the above assigned individuals (section 2) for official business – related expenditures for hotel, parking, ferry, taxi, meals, gas, airline tickets, emergency city vehicle repairs and other travel related expenses as authorized by the Mayor or City Administrator. In addition the assigned individual may use the City credit card for conference and class registrations. Out of state travel and out of state registration require the Department Head to obtain the Mayor's pre-approval.
- Purchases: The assigned credit cards may be used for ordering supplies, including on-line purchases, under \$1,000 for City purposes, when pre-approved by the Department Director. The City Clerk's credit card shall be utilized for on-line purchases over \$1,000 with pre-approval by the City Clerk and City Administrator.
- Purchases where an open charge account exists may be utilized for convenience at the time of purchase with the approval of the City Administrator.
- Credit Limit: The credit limit for each assigned City credit card shall be \$1,000 for employees. The credit limit for the City Administrator, Fire Chief and Public Works Director shall be \$5,000. **The credit limit for the City Clerk, Police Chief and Assistant Police Chief shall be \$10,000.**

Section 2: Except as specifically amended herein, all other provisions of Chapter 27 of the Grandview Personnel Manual remain unchanged.

PASSED by the **CITY COUNCIL** and **APPROVED** by the **MAYOR** at its regular meeting on March 10, 2026.

MAYOR

ATTEST:

CITY CLERK

APPROVED AS TO FORM:

CITY ATTORNEY

RESOLUTION NO. 2026-18

**A RESOLUTION OF THE CITY OF GRANDVIEW, WASHINGTON,
ACCEPTING THE FUEL BID FROM VALLEY WIDE COOPERATIVE FOR THE
YEAR BEGINNING APRIL 1, 2026 TO MARCH 31, 2027**

WHEREAS, the City has solicited bids from qualified fuel companies to provide vehicle fuel to the City of Grandview for the year beginning April 1, 2026 to March 31, 2027; and,

WHEREAS, the City received two (2) bids in response to such solicitation; and,

WHEREAS, the City Council finds and determines that Valley Wide Cooperative is the lowest responsible bidder;

NOW, THEREFORE, BE IT RESOLVED BY THE CITY COUNCIL OF THE CITY OF GRANDVIEW, WASHINGTON, as follows:

That the bid submitted by the Valley Wide Cooperative, as set forth in the attached bid, is hereby approved and accepted, and the Mayor is hereby authorized to execute any and all documents necessary or appropriate to accomplish such transaction.

PASSED by the **CITY COUNCIL** and **APPROVED** by the **MAYOR** at its regular meeting on March 10, 2026.

MAYOR

ATTEST:

CITY CLERK

APPROVED AS TO FORM:

CITY ATTORNEY

BID FORM

I/We the undersigned, having read all requirements of this call for bids, together with all the special provisions and specifications set forth herein, do agree in every particular, and will furnish petroleum products and documentation as specified herein as follows:

Bidder's Major Supplier is: Cenex and the OPIS price adjustment reference city shall be: ___ Seattle; ___ Spokane; ___ Moses Lake; ___ Portland; or Pasco.

	<u>Regular Unleaded</u>	<u>Diesel</u>
Estimated Annual Gallons:	<u>28,000</u>	<u>14,500</u>
Seller's Cost Per Gallon for Monday, March 2, 2026 :	<u>2.9779</u>	<u>3.7983</u>
Margin Bid Above Seller's Cost Excluding Taxes:	<u>.14</u>	<u>.14</u>
TOTAL:	<u>3.1179</u>	<u>3.9383</u>

Location(s) of 24-Hour Pumping Facilities with a minimum number of two fueling islands:

1) 940 E. Wine Country Rd, Grandview WA 98930. 2) 1720 Eastway Dr, Sunny Side WA, 98941
3) 1000 Bennett Ave, Prosser, WA 99350

Description of Method to be Used to Meet Bid Specifications B Through E: customer will be issued fuel cards to meet requirements

This bid shall be valid for a period of thirty (30) days from the bid opening date.

Bidders Name: Roman Chavez

Company Name: Valley wide Cooperative

Mail Address: 940 E. Wine Country Rd, Grandview, WA 98930 Suite C.

Telephone Number: 509-778-2604 Fax Number: _____

Signature of Authorized Official: Roman Chavez

Title of Official: Regional Manager

**CITY OF GRANDVIEW
INSTRUCTIONS TO BIDDERS
FUEL BID**

SUBMISSION OF BIDS

Sealed bids shall be addressed or delivered to:
City Clerk
City of Grandview
207 West Second Street
Grandview, WA 98930

The bid envelope shall be clearly marked "FUEL BID."

CLOSING DATE

Bids will be received until **11:00 a.m., Wednesday, March 4, 2026.**

BID OPENING

Bids will be opened and publicly read aloud in the Council Chambers, City Hall, 207 West Second Street, Grandview, Washington, at **11:00 a.m., Wednesday, March 4, 2026**, at which time interested parties may be present to witness the bid opening.

ACCEPTABILITY OF BIDS

Bids must be submitted on the City of Grandview bid form and placed in a sealed envelope. The words "Fuel Bid" must be clearly marked on the front of the envelope.

The bid form must contain the bidders business or home address and must be signed by a duly authorized official.

Bids that are unsigned, incomplete, illegible, unbalanced, obscure, or with any other irregularities may be rejected. The City Council reserves the right to accept any or all bids or any portion thereof and to waive minor irregularities and informalities, at the City's discretion.

The bid shall be valid for thirty (30) calendar days following the bid opening date.

Prices shall be filled in where indicated on the bid form. Prices shall be net, free on board (FOB) Grandview unless otherwise stated, and shall not include any taxes, nor shall they be subject to any discounts or other conditions.

BID SPECIFICATIONS

The products shall conform to the requirements of the Tentative Specifications for Gasoline as approved by the American Society for Testing Materials, ASTM Designation D 439-81. The minimum octane rating shall conform to the Average Knock Index (R+M/2) as follows:

"Regular Unleaded" Minimum Octane 87

The seasonal variation in volatility and vapor pressure shall be substantially maintained in accordance with the schedule set up for the State of Washington as set forth in ASTM specifications above noted.

Bidders shall give the following information relative to each grade of gasoline bid in the spaces provided:

1. The name of the brand under which the gasoline is offered for sale to the general public:

"Regular Unleaded" gasoline: Cenex

"Diesel": Cenex

2. The nature of any added substances other than volatile petroleum hydrocarbons.

"Regular Unleaded" gasoline:

3. The guaranteed average and minimum Octane Number for "Regular Unleaded" grade:

"Regular Unleaded" Average 87 Minimum 87

4. The guaranteed average and maximum Sulphur Content in "Diesel"

Grade No. 2 : Average less than 15 ppm Minimum less than 15 ppm

All bids shall be made for a card controlled fuel purchase system for regular gasoline, unleaded gasoline, and diesel fuel. Ease of City staff operation and accounting time for this system will be taken into consideration when determining the low bid.

- A. There must be a "card lock" pumping location in the City of Grandview with 24 hour service and a **minimum number of two fueling islands**.
- B. At the time of purchase, the vehicle, person obtaining fuel, and odometer reading must be identified and recorded by the supplier.
- C. The supplier shall furnish two numbered cards for each vehicle. There are approximately 70 vehicles.
- D. The supplier shall provide security codes for all City vehicle operators, to be used in conjunction with the vehicle cards for purchases of fuel. There are approximately 60 employees.
- E. The supplier must provide a monthly accounting that must include an itemized account detailing the activity of each vehicle. This accounting as a minimum must sub-total by vehicle and list: date, time, vehicle card number, person obtaining fuel, odometer reading, type of fuel, gallons and actual price charged. Each monthly billing shall also include copies of the appropriate weekly OPIS publication for that billing cycle or the major supplier's price change letter.

PRICING, PRICE ESCALATION - BULK FUELS

- A. Contract prices will be allowed to increase or decrease after bid opening and during the term of the contract. All contract price adjustments shall be based on the change in the vendor's major supplier's listed price for one of the following P.A.D cities: Seattle, Spokane, Portland, Moses Lake, or Pasco as reported in the weekly publications, Oil Price Information Service (OPIS) published by the United Communications Group. A second method shall be to reference the major supplier's price change letter which reflects changes at the location of your plant.
- B. Bidder shall specify his supplier (See Requirements and the Bid Proposal) and the price adjustment reference city (Seattle, Spokane, Portland, Moses Lake, or Pasco) to be used for contract price adjustments on the Bid Proposal. Only one supplier and one reference city may be specified by each bidder. **A copy of the appropriate OPIS publication, or in the case of the second method (above) the calculation price shall be your buying price per gallon with Federal and State taxes excluded, used as a bidding reference and must be included with the bid submitted.** If OPIS does not list one or more supplier product prices for a reference city, the listed average price for that city shall be used.
- C. Any upward or downward change in the major supplier's prices from one OPIS publication to the next, or change in the price from the major supplier's price change letter will be added or subtracted from the previous contract price but the margin as bid will remain the same. It is important to note that the difference between the Bid Price and the selected OPIS Price or major suppliers price change letter at the time of the bid, must be maintained throughout the period of the contract. The effective date of the price change will be on Thursday following the date of the publication which reflects the price change.
- D. The first price adjustment shall be based on the difference in the prices for the last OPIS publication issue or major supplier's price change letter prior to the effective date of the contract. Any upward or downward change in the comparison of prices will be added to or subtracted from bid prices with the effective date of such change to be the **first of April 2026** rather than the following Thursday.

BIDDERS QUALIFICATIONS

Bidders may be required to submit evidence as to their ability to supply and provide the above defined service and should be prepared to satisfy the City as to their competency to meet the specifications and conditions. Bidders, when required by law, shall be licensed and bonded by the State of Washington.

CONDITIONS

The bidder is fully responsible for obtaining all information for the preparation of this bid.

LIABILITY

The bidder shall ensure that the City, its officers and employees, are held harmless from any liability whatsoever arising out of the bidder's performance or non-performance of the term of this bid, including the performance and non-performance by any sub-contractor or employee.

CONTRACTORS PROTECTIVE CLAUSE

There shall be no obligation to deliver any or all of the products included in this proposal in the customary manner when such deliveries are prevented or hindered by Act of God, fire, strike, partial or total interruptions or loss or shortage of transportation facilities, or by other similar or different acts of civil or military authorities, or by other like causes beyond the control of the contractor.

FURTHER INFORMATION

Contact Anita Palacios, City Clerk, 207 West Second Street, Grandview, Washington, 98930, or PH: (509) 882-9200, email anitap@grandview.wa.us.

CHS Refined Fuels Rack Price Notification

Rack Pricing For: VALLEY WIDE COOPERATIVE INC

MT MISSOULA-CN/R/AD Effective: 03/02/2026 18:00

Product-Branded	Change	Price	Product-Branded	Change	Price
ULSD15 #1 CLEAR	+0.1768	3.3080	ULSD15 #1 DYED	+0.1767	3.3120
ULSD15 #2 CLEAR	+0.1767	2.8231	ULSD15 #2 DYED	+0.1768	2.8272
CENEX® ROADMASTER XL	+0.1768	2.8706	CENEX® RUBY FIELDMASTER	+0.1768	2.8747
CENEX® WINTERMASTER CLEAR	+0.1768	3.2205	CENEX® WINTERMASTER DYED	+0.1768	3.2246
ULSD15 #2 CLEAR WA IV	+0.1767	2.8381	CENEX® RUBY FIELDMASTER SE	+0.1768	3.0275
CENEX® ROADMASTER XL SE	+0.1768	3.0234	ULSD15 #2 DYED WA IV	+0.1768	2.8422
CENEX® RUBY FIELDMASTER WA IV	+0.1768	2.8897	CENEX® ROADMASTER XL WA IV	+0.1768	2.8856
UNLEADED 87 10% ETH	+0.1218	2.2951	UNLEADED 89 3-WAY 10% ETH	+0.1193	2.5335
UNLEADED 91 3-WAY 10% ETH	+0.1217	2.7688	UNLEADED 93 10% ETH	+0.1216	2.9708
UNLEADED 91	+0.1215	3.0511			

MT LOGAN-CN/R/AD Effective: 03/02/2026 18:00

Product-Branded	Change	Price	Product-Branded	Change	Price
ULSD15 #1 CLEAR	+0.1805	3.3848	ULSD15 #1 DYED	+0.1804	3.3888
ULSD15 #2 CLEAR	+0.1804	2.8797	ULSD15 #2 DYED	+0.1804	2.8837
CENEX® ROADMASTER XL	+0.1804	2.9272	CENEX® RUBY FIELDMASTER	+0.1804	2.9312
CENEX® WINTERMASTER CLEAR	+0.1804	3.2912	CENEX® WINTERMASTER DYED	+0.1804	3.2953
ULSD15 #2 CLEAR WA IV	+0.1804	2.8947	CENEX® RUBY FIELDMASTER SE	+0.1804	3.0932
CENEX® ROADMASTER XL SE	+0.1804	3.0892	#1 CENEX® RUBY FIELDMASTER	+0.1804	3.4363
#1 CENEX® ROADMASTER XL	+0.1804	3.4322	ULSD15 #2 DYED WA IV	+0.1804	2.8987
CENEX® RUBY FIELDMASTER WA IV	+0.1804	2.9462	CENEX® ROADMASTER XL WA IV	+0.1804	2.9422
UNLEADED 87 10% ETH	+0.1229	2.3160	UNLEADED 89 3-WAY 10% ETH	+0.1209	2.5574
UNLEADED 91 3-WAY 10% ETH	+0.1226	2.7897	UNLEADED 93 10% ETH	+0.1227	2.9918
UNLEADED 91	+0.1215	3.0676			

WA HILLYARD-HFT/R/AD Effective: 03/02/2026 18:00

Product-Branded	Change	Price	Product-Branded	Change	Price
ULSD15 #1 CLEAR	+0.1520	4.4720	ULSD15 #1 DYED	+0.1519	4.4760
ULSD15 #2 CLEAR	+0.1343	3.7281	ULSD15 #2 DYED	+0.1343	3.7321
CENEX® ROADMASTER XL	+0.1343	3.7755	CENEX® RUBY FIELDMASTER	+0.1343	3.7796
CENEX® ROADMASTER XL CFI	+0.1343	3.8005	UNLEADED 92 10% ETH	+0.0906	3.2853
ULSD15 #2 CLEAR CFI	+0.1343	3.7531	ULSD15 #2 DYED CFI	+0.1343	3.7571
CENEX® RUBY FIELDMASTER CFI	+0.1343	3.8046	UNLEADED 87 10% ETH	+0.0724	2.8630
UNLEADED 89 3-WAY 10% ETH	+0.0888	3.1071			

WA PASCO-TWB/R/AD Effective: 03/02/2026 18:00

Product-Branded	Change	Price	Product-Branded	Change	Price
ETHANOL E85	+0.0982	2.3719	ULSD15 #1 CLEAR	+0.1353	4.3033
ULSD15 #1 DYED	+0.1354	4.3074	ULSD15 #2 CLEAR	+0.1354	3.7983
ULSD15 #2 DYED	+0.1353	3.8023	CENEX® ROADMASTER XL	+0.1354	3.8458
CENEX® RUBY FIELDMASTER	+0.1354	3.8498	CENEX® ROADMASTER XL CFI	+0.1354	3.8658
ULSD15 #2 CLEAR B5	+0.1440	3.8388	CENEX® RUBY FIELDMASTER B5 CFI	+0.1440	3.9103
CENEX® RUBY FIELDMASTER B20	+0.1451	3.8334	CENEX® ROADMASTER XL B20	+0.1451	3.8294
ULSD15 #2 CLEAR B20	+0.1451	3.7819	UNLEADED 92 10% ETH	+0.0980	3.3443
CENEX® ROADMASTER XL B5	+0.1440	3.8863	CENEX® RUBY FIELDMASTER B5	+0.1440	3.8903
ULSD15 #2 CLEAR CFI	+0.1354	3.8183	ETHANOL	+0.1212	1.9697
ULSD15 #2 DYED CFI	+0.1353	3.8223	CENEX® ROADMASTER XL B5 CFI	+0.1440	3.9063
ULSD15 #2 DYED B5	+0.1439	3.8428	ULSD15 #2 DYED B20	+0.1451	3.7859
CENEX® RUBY FIELDMASTER CFI	+0.1354	3.8698	UNLEADED 87 10% ETH	+0.0982	2.9779

UNLEADED 89 10% ETH +0.0956 3.2276

MT BOZEMAN-P66/RF Effective: 03/02/2026 18:00

Product-Branded	Change	Price	Product-Branded	Change	Price
ULSD15 #1 CLEAR	+0.1805	3.3848	ULSD15 #1 DYED	+0.1804	3.3888
ULSD15 #2 CLEAR	+0.1804	2.8797	ULSD15 #2 DYED	+0.1804	2.8837
ULSD15 #2 CLEAR CFI	+0.1804	2.8947	ULSD15 #2 DYED CFI	+0.1804	2.8987
UNLEADED 87 10% ETH	+0.1229	2.3160	UNLEADED 91 3-WAY 10% ETH	+0.1226	2.7897
UNLEADED 91	+0.1215	3.0676			

WA MOSES LAKE-P66/RF Effective: 03/02/2026 18:00

Product-Branded	Change	Price	Product-Branded	Change	Price
ULSD15 #2 CLEAR	+0.1274	3.7055	ULSD15 #2 DYED	+0.1275	3.7096
UNLEADED 89 10% ETH LAC	+0.0858	3.0617	ULSD15 #2 CLEAR CFI	+0.1274	3.7355
ULSD15 #2 DYED CFI	+0.1275	3.7396	UNLEADED 87 10% ETH LAC	+0.0857	2.8293
UNLEADED 91 LAC	+0.0857	3.6576	UNLEADED 92 10% ETH LAC	+0.0858	3.2940

OR UMATILLA-TWB/RF Effective: 03/02/2026 18:00

Product-Branded	Change	Price	Product-Branded	Change	Price
ULSD15 #1 CLEAR	+0.1451	4.0008	ULSD15 #1 DYED	+0.1451	4.0048
ULSD15 #2 CLEAR B5	+0.1403	3.3042	ULSD15 #2 CLEAR B20	+0.1403	3.3042
ULSD15 #2 DYED B5	+0.1404	3.3083	ULSD15 #2 DYED B20	+0.1404	3.3083

WA SEATTLE-BP/RF Effective: 03/02/2026 18:00

Product-Branded	Change	Price	Product-Branded	Change	Price
ULSD15 #1 CLEAR	+0.1386	4.2601	ULSD15 #1 DYED	+0.1387	4.2642
ULSD15 #2 CLEAR	+0.1387	3.7046	ULSD15 #2 DYED	+0.1386	3.7086
ULSD15 #2 CLEAR B20	+0.1312	4.0430	UNLEADED 92 10% ETH	+0.1012	3.4436
ULSD15 #2 DYED B20	+0.1312	4.0471	UNLEADED 87 10% ETH	+0.0892	3.0916
UNLEADED 87 BLEND CLEAR	+0.0897	3.4127	UNLEADED 89 3-WAY 10% ETH	+0.1021	3.3052

WA TACOMA-PAR/RF/PR Effective: 03/02/2026 18:00

Product-Branded	Change	Price	Product-Branded	Change	Price
ULSD15 #2 CLEAR	+0.1394	3.7656	ULSD15 #2 DYED	+0.1394	3.7697
CENEX® ROADMASTER XL	+0.1394	3.8131	CENEX® RUBY FIELDMASTER	+0.1394	3.8171
UNLEADED PREMIUM BLEND GRADE 10% ETH	+0.0838	3.4818	UNLEADED 89	+0.0981	3.7876
UNLEADED 92	+0.1058	4.4737	UNLEADED 87 10% ETH	+0.0982	3.0877
UNLEADED 87 BLEND CLEAR	+0.0981	3.7671	UNLEADED 89 3-WAY 10% ETH	+0.0837	3.3291

RESOLUTION NO. 2026-19

**A RESOLUTION OF THE CITY OF GRANDVIEW, WASHINGTON,
ACCEPTING A REQUEST FROM HUGO GARIBAY FOR ANNEXATION OF PARCEL
NOS. 230927-11424 AND 230927-11425 LOCATED AT 160 HICKORY ROAD,
GRANDVIEW, YAKIMA COUNTY, WASHINGTON TO THE CITY OF GRANDVIEW**

WHEREAS, Hugo Garibay submitted a Letter of Intent to the City requesting annexation of Parcel Nos. 230927-11424 and 230927-11425 located at 160 Hickory Road, Grandview, Yakima County, Washington to the City of Grandview; and

WHEREAS, on March 10, 2026, the City Council was presented with the Letter of Intent and Petition for Annexation and reviewed the proposed annexation,

NOW, THEREFORE, BE IT RESOLVED BY THE CITY COUNCIL OF THE CITY OF GRANDVIEW, AS FOLLOWS:

Section 1. The City of Grandview hereby accepts the request for annexation subject to the following conditions:

- That the annexation be accepted as proposed on Exhibit "A" attached hereto.
- That the City requires the simultaneous adoption of the City's zoning regulations consistent with the Urban Growth Area Future Land Use Designation: R-2 Medium Density Residential for the proposed annexation.
- That the City requires the assumption of an appropriate share of all existing City indebtedness by the area to be annexed.

Section 2. Staff is hereby directed to present the Petition for Annexation to the Hearing Examiner who shall receive and examine available information, conduct a public hearing, prepare a record thereof and enter findings of fact and conclusions based upon those facts, together with a recommendation to the City Council.

PASSED by the **CITY COUNCIL** and **APPROVED** by the **MAYOR** at its regular meeting on March 10, 2026.

MAYOR

ATTEST:

CITY CLERK

APPROVED AS TO FORM:

CITY ATTORNEY



Assessor

Planning

County Roads

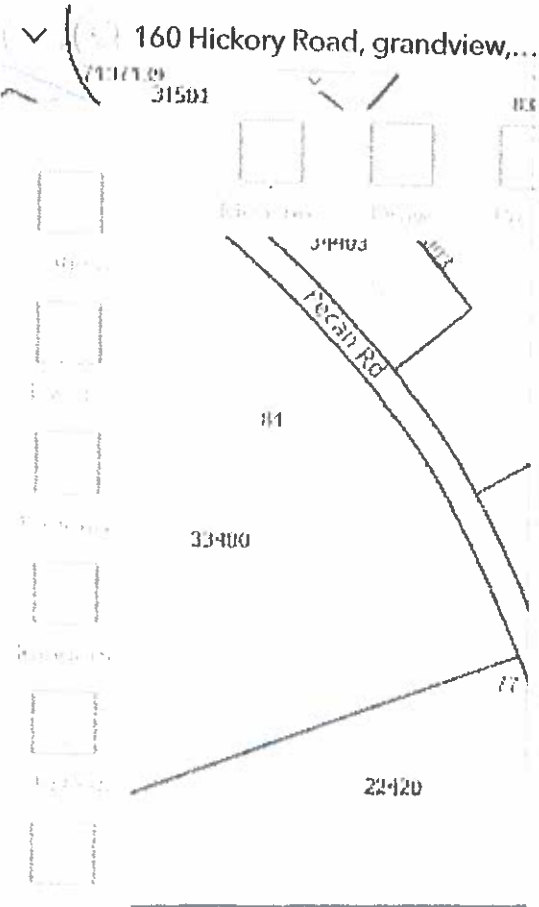

Click on Parcel to Get

230927-11424

Zoom to

PROPERTY INFORMATION	
Parcel Owner(s):	HUGO GARIIBAY
Parcel Address:	160 HICKORY RD, GRANDVIEW, WA 98930
Parcel Number:	23092711424 Parcel Size: 0.39 Acre(s)
Property Use:	11 Single Unit (Neighborhood: GV)
TAX AND ASSESSMENT INFORMATION	
Tax Year:	2026 Tax Code Area: TCA: 441
Land Value:	\$80,700 Improvement Value: \$64,800
Current Use Value:	\$ CU Improvement: \$
New Construction:	\$ Total Assessed Value: \$145,500

230927-11424
3/8/07 #64

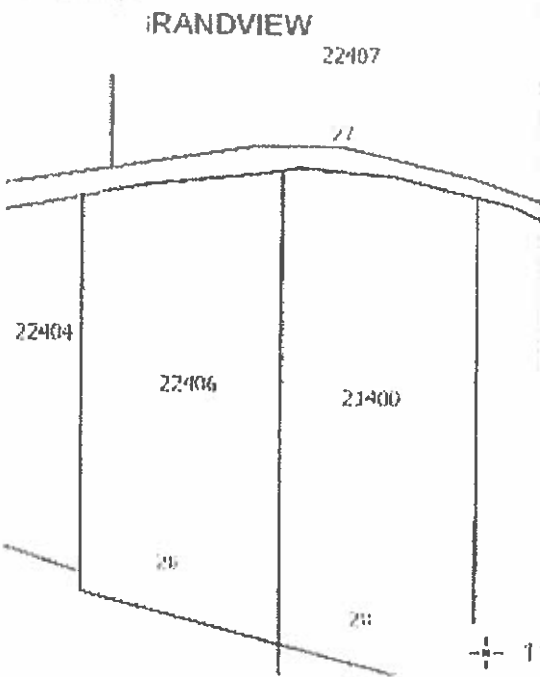
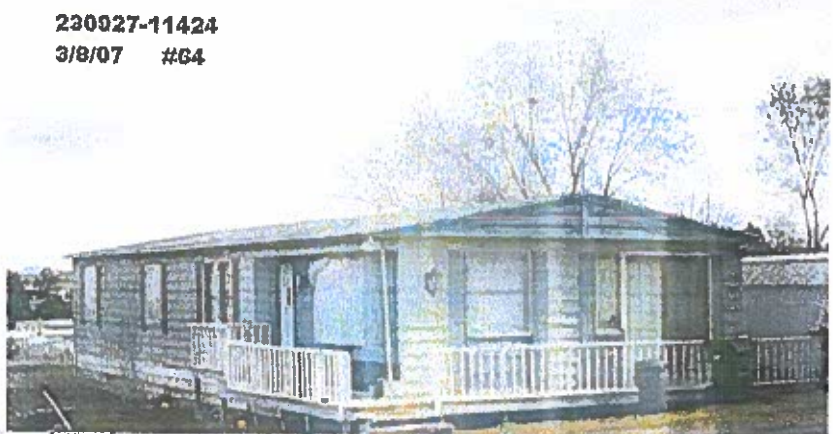

119°55'13.442"W 46°14'34.021"N

200 ft

Powered by Esri

MAP AND PARCEL DATA ARE BELIEVED TO BE ACCURATE, BUT ACCURACY IS NOT GUARANTEED; THIS IS NOT A LEGAL DOCUMENT AND SHOULD NOT BE SUBSTITUTED FOR A TITLE SEARCH. ADDITIONAL SURVEY BLOCKS AVAILABLE



Assessor

Planning

County Roads

160 Hickory Road, grandview, WA 98930
230927-11425

Click on Parcel to Get
230927-11425

Zoom to

PROPERTY INFORMATION			
Parcel Owner(s):	HUGO GARIBAY		
Parcel Address:	160 HICKORY RD. GRANDVIEW, WA 98930		
Parcel Number:	23092711425	Parcel Size:	1.77 Acre(s)
Property Use:	91 Undeveloped Land (Neighborhood: GV)		
TAX AND ASSESSMENT INFORMATION			
Tax Year:	2026	Tax Code Area:	TCA: 441
Land Value:	\$87,800	Improvement Value:	\$0
Current Use Value:	\$	CU Improvement:	\$
New Construction:	\$	Total Assessed Value:	\$87,800

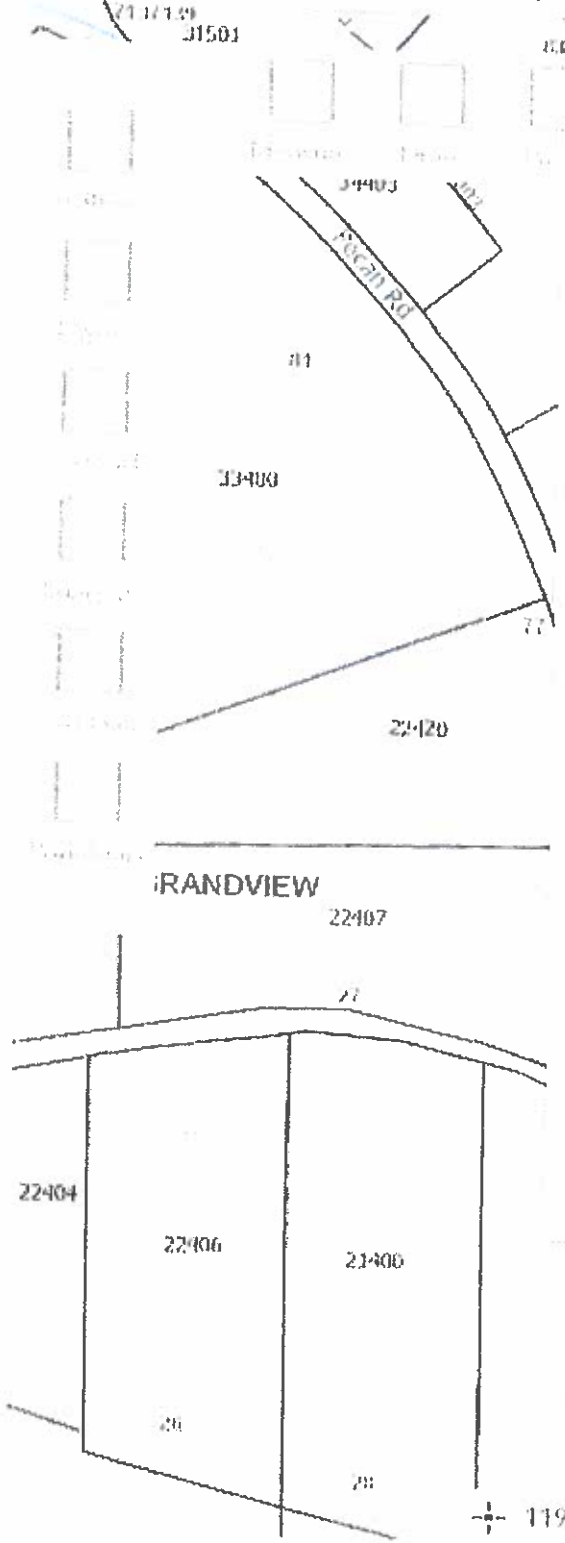

119°55'09.847"W 46°14'34.586"N

200 ft

MAP AND PARCEL DATA ARE BELIEVED TO BE ACCURATE, BUT ACCURACY IS NOT GUARANTEED; THIS IS NOT A LEGAL DOCUMENT AND SHOULD NOT BE SUBSTITUTED FOR A TITLE SEARCH. ADDITIONAL SURVEY EVIDENCE MAY

Powered by Esri