

**GRANDVIEW CITY COUNCIL
COMMITTEE-OF-THE-WHOLE
MEETING AGENDA
TUESDAY, MARCH 10, 2026**



This meeting will be held in person
and will also be available via teleconference.

PLEASE NOTE: The maximum occupancy of the Council Chambers is 49 individuals at one time. Access to exits must be kept clear to ensure everyone in the Chambers can safely exit in the event of an emergency.

COMMITTEE-OF-THE-WHOLE MEETING – 6:00 PM

PAGE

- 1. CALL TO ORDER**
- 2. ROLL CALL**
- 3. NEW BUSINESS**
 - A. Resolution authorizing the Mayor to sign a Recreational Use Permit by and between the City of Grandview and the Lower Valley Cal Ripken League 1-7
 - B. Resolution declaring certain City property from the Police Department as surplus and authorizing disposal by public auction, sale or trade (vehicle) 8-9
 - C. Resolution declaring certain City property from the Police Department as surplus and authorizing disposal by public auction, sale, trade or disposal (computers) 10-11
 - D. Resolution amending Section 27.04(A) of the Credit Card Use Policy within the City of Grandview Personnel Policy Manual increasing credit card limits for the Police Chief and Assistant Police to \$10,000 12-16
 - E. Resolution accepting the fuel bid from Valley Wide Cooperative for the year beginning April 1, 2026 to March 31, 2027 17-37
 - F. Resolution accepting a request from Hugo Garibay for annexation of Parcel Nos. 230927-11424 and 230927-11425 located at 160 Hickory Road, Grandview, Yakima, County, Washington to the City of Grandview 38-49
- 4. CITY ADMINISTRATOR AND/OR STAFF REPORTS**
- 5. MAYOR & COUNCILMEMBER REPORTS**
 - A. Sub-Committee Updates
- 6. ADJOURNMENT**

The City of Grandview Committee-of-the-Whole and Regular Council Meetings scheduled for Tuesday, March 10, 2026 at 6:00 pm and 7:00 pm will be held in person and will also be available via teleconference.

Please join the meeting from your computer, tablet or smartphone.

Join Zoom Meeting

<https://us06web.zoom.us/j/84214652389?pwd=ZikMVr11qx3rOxYmtb8Hr0ZxFfRama.1>

To join via phone: +1 253 215 8782

Meeting ID: 842 1465 2389

Passcode: 913544

**CITY OF GRANDVIEW
AGENDA ITEM HISTORY/COMMENTARY
COMMITTEE-OF-THE-WHOLE MEETING**

ITEM TITLE

Resolution authorizing the Mayor to sign a Recreational Use Permit by and between the City of Grandview and the Lower Valley Cal Ripken League

AGENDA NO.: New Business 3 (A)

AGENDA DATE: March 10, 2026

DEPARTMENT

Parks & Recreation Department

FUNDING CERTIFICATION (City Treasurer)
(If applicable)

DEPARTMENT DIRECTOR REVIEW

Gretchen Chronis, Parks & Recreation Director

CITY ADMINISTRATOR



MAYOR



ITEM HISTORY (Previous council reviews, action related to this item, and other pertinent history)

Washington Cities Insurance Authority strongly recommends that the City enter into Recreational Use Permits between those athletic organizations that are utilizing City owned recreational facilities to conduct their respective programs.

ITEM COMMENTARY (Background, discussion, key points, recommendations, etc.) Please identify any or all impacts this proposed action would have on the City budget, personnel resources, and/or residents.

Attached is the Recreational Use Permit between the City and the Lower Valley Cal Ripken League for the 2026 season. Baseball League Coordinator Alicia Trevino of the Lower Valley Cal Ripken League has reviewed and signed the agreement.

ACTION PROPOSED

Move resolution authorizing the Mayor to sign a Recreational Use Permit by and between the City of Grandview and the Lower Valley Cal Ripken League to the March 10, 2026 regular Council meeting for consideration.

RESOLUTION NO. 2026-_____

**A RESOLUTION OF THE CITY OF GRANDVIEW, WASHINGTON,
AUTHORIZING THE MAYOR TO SIGN A RECREATIONAL USE PERMIT
BY AND BETWEEN THE CITY OF GRANDVIEW AND THE
LOWER VALLEY CAL RIPKEN LEAGUE**

WHEREAS, the City of Grandview and the Lower Valley Cal Ripken League desire to enter into a Recreational Use Permit regarding the use of the Ralph Scott Memorial Ballfields at the Country Park Events Center;

NOW, THEREFORE, BE IT RESOLVED BY THE CITY COUNCIL OF THE CITY OF GRANDVIEW, WASHINGTON, as follows:

The Mayor is hereby authorized to sign a Recreational Use Permit by and between the City of Grandview and the Lower Valley Cal Ripken League in the form as is attached hereto and incorporated herein by reference.

PASSED by the **CITY COUNCIL** and **APPROVED** by the **MAYOR** at its regular meeting _____, 2026.

MAYOR

ATTEST:

CITY CLERK

APPROVED AS TO FORM:

CITY ATTORNEY

RECREATIONAL USE PERMIT

By and Between City of Grandview and Lower Valley Cal Ripken League

This Agreement entered into this 10th day of March, 2026, by and between the City of Grandview, and Lower Valley Cal Ripken League for the uses and purposes stated herein and below.

1. Recitals

A. The City of Grandview, hereafter called the "City" is a municipal corporation of the State of Washington, with City Hall located at 207 W. 2nd Street, Grandview, WA 98930.

B. Lower Valley Cal Ripken League, hereafter called "Baseball League" is a non-profit organization with organized and stated purposes of organizing baseball competition between teams of the organization.

C. City owns Ralph Scott Memorial Ball Fields at the Country Park Events Center. Such facilities include baseball fields suitable for competition, hereafter called the "Baseball Facility".

D. City and Baseball League desire to enter into a Recreational Use Permit regarding the use of Baseball Facility.

2. Agreement

Wherefore, in consideration of mutual covenants, conditions and promises herein, the parties agree as follows:

Responsibilities of Baseball League:

A. Baseball League seeks to gain access for the use of Baseball Facility to conduct a program of baseball, in accordance with its own rules and regulations.

B. Baseball League shall pay the City a Recreational Use Permit fee of \$25 for each use of the ball field lights. An accurate account of each use of the ball field lights will be recorded by the league and submitted to the City at the end of the season for appropriate billing. The Recreational Use Permit authorizes Baseball League to use the Baseball Facility as mutually scheduled between March 10 and July 31, 2026. Baseball League acknowledges that City sponsored programs and community events have scheduling priority over Baseball League's use of the Baseball Facility under this Agreement, and that Baseball League may not use the Baseball Facility if such use conflicts with a City sponsored program or community event. Baseball League shall not use the Baseball Facility additionally without first obtaining further written permission from the City and the payment of additional fees as established by the City.

C. At no time shall Baseball League participants, coaches, officials, spectators, vendors, or any other people drive or park any vehicles on the Baseball Facility, except maintenance and emergency response vehicles. No vehicles shall be allowed on the field or the grass at the Country Park Events Center, except maintenance and emergency response vehicles. All vehicles must be parked in spaces designated for parking. Only individuals with a current Washington State Disabled Parking Permit will be allowed to park in designated disabled parking areas. All other vehicles associated with the Baseball League will park in the main parking lot at the Country Park Events Center.

D. Baseball League shall be solely and completely responsible for maintaining the dirt infields, facility fencing, dugout shelters, benches, storage units/areas and on-site equipment in a clean, neat and safe condition. The City will be responsible for mowing and trimming of grass, restroom maintenance and garbage dumpsters. Baseball League shall provide routine litter clean-up and shall properly dispose of all trash on or surrounding the Baseball Facility, including parking areas, during the period of time that Baseball League shall be using the Baseball Facility. Baseball League shall be responsible for any damage that occurs to the Baseball Facility as a result or incidental to, Baseball League's use of the Baseball Facility under this Agreement. It is the responsibility of the Baseball league to keep all participants and spectators out of the livestock building and amphitheater areas. Baseball League will be allowed to engage in off-season field and structure maintenance of the baseball facility as scheduled through the parks and recreation department.

E. Should Baseball League desire to make improvements and/or install equipment for use on the Baseball Facility, Baseball League shall seek prior written approval of the City before any equipment may be installed. Baseball League shall be solely responsible to ensure that said equipment meets the requirements of the U.S. Consumer Products Commission or other state or federal agency charged with the establishment of safety standards for such equipment. Upon installation of said equipment, such equipment shall remain the sole property of the City unless otherwise specifically agreed upon in writing by both parties.

F. Baseball League is aware of and will abide by all elements of the Grandview Municipal Code of Chapter 12.20 (Park Code).

G. Indemnification/Hold Harmless. User shall defend, indemnify and hold harmless the City of Grandview, its officers, officials, employees and volunteers from and against any and all claims, suits, actions, or liabilities for injury or death of any person, or for loss or damage to property, which arises out of the use of Premises or from any activity, work or thing done, permitted, or suffered by User in or about the Premises, except only such injury or damage as shall have been occasioned by the sole negligence of the City of Grandview.

H. Insurance Term. User shall procure and maintain for the duration of the use or rental period insurance against claims for injuries to persons or damage to property which may arise from or in connection with the use of the facilities and the activities of the User and his or her guests, representatives, volunteers and employees.

I. **No Limitation.** User's maintenance of insurance as required by the Agreement shall not be construed to limit the liability of the User to the coverage provided by such insurance, or otherwise limit the City of Grandview's recourse to any remedy available at law or in equity.

J. **Required Insurance.** User's required insurance shall be as follows: General Liability insurance shall be at least as broad as Insurance Services Office (ISO) occurrence form CG 00 01 covering premises, operations, products-completed operations and contractual liability. The City of Grandview shall be named as an additional insured on User's General Liability insurance policy using ISO Additional Insured-Managers or Lessors of Premises Form CG 20 11 or an endorsement providing at least as broad coverage. The General Liability insurance shall be written with limits no less than \$1,000,000 each occurrence, \$1,000,000 general aggregate. General Liability insurance shall also include coverage for participant liability with limits of not less than \$1,000,000 per occurrence. The insurance policy shall contain or be endorsed to contain that the User's insurance coverage shall be primary insurance as respect the City of Grandview. Any insurance, self-insurance, or self-insured pool coverage maintained by the City of Grandview shall be excess of the User's insurance and shall not contribute with it.

K. **City of Grandview Full Availability of User Limits.** If the User maintains higher insurance limits than the minimums shown above, the City of Grandview shall be insured for the full available limits of Commercial General and Excess or Umbrella liability maintained by the User, irrespective of whether such limits maintained by the User are greater than those required by this contract or whether any certificate of insurance furnished to the City of Grandview evidences limits of liability lower than those maintained by the User.

L. **Certificate of Insurance and Acceptability of Insurers.** The User shall provide a certificate of insurance evidencing the required insurance before using the Premises. Insurance is to be placed with insurers with a current A.M. Best rating of not less than A: VII.

M. **Baseball League has inspected the Baseball Facility and the Country Park Events Center and any equipment located upon such facility, and finds such to be adequate for Baseball Leagues use.** Baseball League and those individuals using such facilities and equipment through Baseball League and this Agreement do so at their own risk.

N. **Under a separate Concession Agreement, the Baseball League shall be entitled to operate a concession stand upon site approved by the City.** Baseball League shall comply with all applicable health code requirements, including but not limited to food preparation, storage, sanitation and waste removal. Baseball League shall be solely responsible for compliance with all applicable laws and regulations pertaining to sales tax and tax reporting.

O. **Users of athletic fields and facilities for youth sports shall comply with the guidance of RCW 28A.600.190 and RCW 28A.600.195 regarding youth sports concussion, head injuries and sudden cardiac arrest.**

P. Baseball League agrees to comply with RCW 49.60.500, made applicable to community athletic programs by RCW 35A.21.350, and prohibit discrimination on the basis of gender with respect to all activities undertaken in connection with this Agreement.

Q. Independent Contractors. The parties are independent contractors, and nothing in this Agreement shall be construed to create a partnership, joint venture or any other relationship than independent contractors. Baseball League shall be and remain in sole charge, supervision and control of all Baseball League activities, games, training and programs. City shall remain in sole charge, supervision and control of all its parks and recreation programs of the City of Grandview.

R. Term of Agreement. The term of this Agreement shall be for the term of the season set forth in Section B above. Notwithstanding termination of this Agreement through expiration of the term, the provisions relating to insurance and indemnification in Section H arising out of occurrences within the coverage of such insurance and/or use of Baseball League's equipment at any time, shall survive termination of this Agreement.

S. Termination. Either party may terminate this Agreement for any reason upon thirty (30) days written notice to the other. In the event Baseball League fails to abide by the terms and conditions of this Agreement or in the event of an Emergency, the City may terminate this Agreement upon such terms and at such time as the City deems necessary and appropriate, provided notice of termination for cause shall be provided to Baseball League. For purposes of this section, the term "Emergency" means any changes of the Comprehensive Plan or Parks & Recreation Plan mandated by governmental authorities and agencies with jurisdiction. Notwithstanding an early termination of this Agreement, the provisions relating to insurance and indemnification in Sections G and H arising out of occurrences within the coverage of such insurance and/or use of Baseball League's equipment at any time, shall survive termination of this Agreement.

T. Entire Agreement. This Agreement, with Baseball League's application for use of City's park facilities, constitutes the entire agreement of the parties, and shall not be amended except in writing signed by both parties. All terms and provisions of the City's application for use of park facilities shall apply to this Agreement and are incorporated herein by this reference. In the event of conflict between this Agreement and the terms and provisions of such application, the terms of this Agreement shall control.

U. Assignment. This Agreement and the terms and provisions herein are personal to Baseball League and shall not be assigned to any third party without the written authorization of the City, which approval shall not be unreasonably withheld.

Wherefore, this Agreement is deemed executed and effective on the date first referenced above.

City of Grandview

Baseball League

By: _____
Mayor Ashley Lara

By: 
Baseball League Coordinator

ATTEST:

By: _____
Anita Palacios, City Clerk

APPROVED AS TO FORM:

By: _____
City Attorney

**CITY OF GRANDVIEW
AGENDA ITEM HISTORY/COMMENTARY
COMMITTEE-OF-THE-WHOLE MEETING**

ITEM TITLE

Resolution declaring certain City property from the Police Department as surplus and authorizing disposal by public auction, sale or trade (vehicle)

AGENDA NO.: New Business 3 (B)

AGENDA DATE: March 10, 2026

DEPARTMENT

Police Department

FUNDING CERTIFICATION (City Treasurer)
(If applicable)

DEPARTMENT DIRECTOR REVIEW

Kal Fuller, Police Chief

CITY ADMINISTRATOR



MAYOR

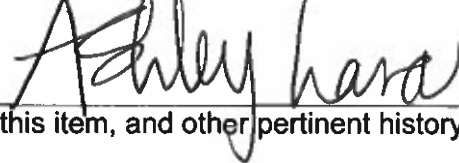

ITEM HISTORY (Previous council reviews, action related to this item, and other pertinent history)

ITEM COMMENTARY (Background, discussion, key points, recommendations, etc.) Please identify any or all impacts this proposed action would have on the City budget, personnel resources, and/or residents.

The Police Department has the following vehicle which is no longer needed for the conduct of City business and is being recommended for surplus:

- 1992 Ford Armored Truck, VIN #1FDXK74P1NVA27075 (former SWAT vehicle)

ACTION PROPOSED

Move a resolution declaring certain City property from the Police Department as surplus and authorizing disposal by public auction, sale or trade (vehicle) to the March 10, 2026 regular Council meeting for consideration.

RESOLUTION NO. 2026-_____

**A RESOLUTION OF THE CITY OF GRANDVIEW, WASHINGTON,
DECLARING CERTAIN CITY PROPERTY FROM THE POLICE DEPARTMENT
AS SURPLUS AND AUTHORIZING DISPOSAL BY PUBLIC AUCTION,
SALE OR TRADE**

WHEREAS, the Police Department has a vehicle that have outlived its useful life and is no longer needed for the conduct of City business; and,

WHEREAS, the City Council has determined that it is in the best interest of the City that the foregoing vehicle be declared surplus and disposed of;

NOW THEREFORE, BE IT RESOLVED BY THE CITY COUNCIL OF THE CITY OF GRANDVIEW, as follows:

Section 1. The following vehicle is hereby declared to be surplus:

- 1992 Ford Armored Truck, VIN #1FDXK74P1NVA27075 (former SWAT vehicle)

Section 2. City staff is authorized to dispose of the vehicle described in section 1 of this resolution by public auction, sale or trade for an amount that represents a fair market value of the vehicle.

Section 3. The City Administrator is authorized to establish a minimum sale/trade-in price that reflects a fair market value of the vehicle described in section 1 of this resolution as deemed necessary to protect the City's interests.

PASSED by the **CITY COUNCIL** and **APPROVED** by the **MAYOR** at a special meeting on _____, 2026.

MAYOR

ATTEST:

CITY CLERK

APPROVED AS TO FORM:

CITY ATTORNEY

**CITY OF GRANDVIEW
AGENDA ITEM HISTORY/COMMENTARY
COMMITTEE-OF-THE-WHOLE MEETING**

ITEM TITLE

Resolution declaring certain City property from the Police Department as surplus and authorizing disposal by public auction, sale, trade or disposal (computers)

AGENDA NO.: New Business 3 (C)

AGENDA DATE: March 10, 2026

DEPARTMENT

Police Department

FUNDING CERTIFICATION (City Treasurer)
(If applicable)

DEPARTMENT DIRECTOR REVIEW

Kal Fuller, Police Chief

CITY ADMINISTRATOR

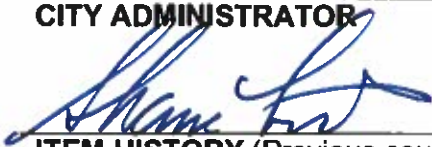

MAYOR

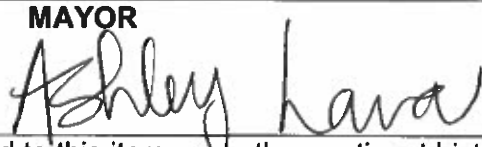

ITEM HISTORY (Previous council reviews, action related to this item, and other pertinent history)

The Police Department has desktop computers and laptops on capital replacement schedules. The desktop computers and laptops are rotated out after 4-7 years and then surplus or destroyed.

ITEM COMMENTARY (Background, discussion, key points, recommendations, etc.) Please identify any or all impacts this proposed action would have on the City budget, personnel resources, and/or residents.

The Police Department has 19 desktop computers that are surplus property. Certinet Systems will scrub the computers of all information in exchange for the component parts. Serial numbers for these computers are as follows:

<u>SERIAL #</u>	<u>BRAND</u>	<u>SERIAL #</u>	<u>BRAND</u>
696742	ALDEN	7146701	ALDEN
7146703	ALDEN	7262401	ALDEN
7262402	ALDEN	7296002	ALDEN
7357101	ALDEN	7357103	ALDEN
7418501	ALDEN	7418502	ALDEN
7418503	ALDEN	7458603	ALDEN
7528001	ALDEN	7528004	ALDEN
64400-02	ALDEN	72-96003	ALDEN
9KLXWB1	DELL	HF50KS1	DELL
MXL4402H6Y	HP		

ACTION PROPOSED

Move a resolution declaring certain City property from the Police Department as surplus and authorizing disposal by public auction, sale, trade or disposal (computers) to the March 10, 2026 regular Council meeting for consideration.

RESOLUTION NO. 2026-__

**A RESOLUTION OF THE CITY OF GRANDVIEW, WASHINGTON,
DECLARING CERTAIN CITY PROPERTY FROM THE POLICE DEPARTMENT
AS SURPLUS AND AUTHORIZING DISPOSAL BY PUBLIC AUCTION,
SALE, TRADE OR DISPOSAL (COMPUTERS)**

WHEREAS, the City no longer has a need for certain personal property that has outlived its useful life and no longer needed for the conduct of City business; and,

WHEREAS, the City Council has determined that it is in the best interest of the City that the foregoing described equipment be declared surplus and disposed of;

NOW THEREFORE, BE IT RESOLVED BY THE CITY COUNCIL OF THE CITY OF GRANDVIEW, as follows:

Section 1. The following Police Department computers and/or laptops are hereby declared surplus and no longer needed for the conduct of City business:

<u>SERIAL #</u>	<u>BRAND</u>	<u>SERIAL #</u>	<u>BRAND</u>
696742	ALDEN	7146701	ALDEN
7146703	ALDEN	7262401	ALDEN
7262402	ALDEN	7296002	ALDEN
7357101	ALDEN	7357103	ALDEN
7418501	ALDEN	7418502	ALDEN
7418503	ALDEN	7458603	ALDEN
7528001	ALDEN	7528004	ALDEN
64400-02	ALDEN	72-96003	ALDEN
9KLXWB1	DELL	HF50KS1	DELL
MXL4402H6Y HP			

Section 2. City staff is authorized to dispose of the equipment described in Section 1 of this resolution by public auction, sale, trade-in or disposal for an amount that represents a fair market value of the equipment.

Section 3. The City Administrator is authorized to establish a minimum sale/trade-in price that reflects a fair market value of the equipment described in Section 1 of this resolution as deemed necessary to protect the City's interests.

PASSED by the **CITY COUNCIL** and **APPROVED** by the **MAYOR** at its regular meeting on _____, 2026.

MAYOR

ATTEST:

CITY CLERK

APPROVED AS TO FORM:

CITY ATTORNEY

**CITY OF GRANDVIEW
AGENDA ITEM HISTORY/COMMENTARY
COMMITTEE-OF-THE-WHOLE MEETING**

ITEM TITLE

Resolution amending Section 27.04(A) of the Credit Card Use Policy within the City of Grandview Personnel Policy Manual increasing credit card limits to \$10,000 for the Police Chief and Assistant Police Chief

AGENDA NO.: New Business 3 (D)

AGENDA DATE: March 10, 2026

DEPARTMENT

City Administration

FUNDING CERTIFICATION (City Treasurer)
(If applicable)

DEPARTMENT DIRECTOR REVIEW

Kal Fuller, Police Chief

CITY ADMINISTRATOR

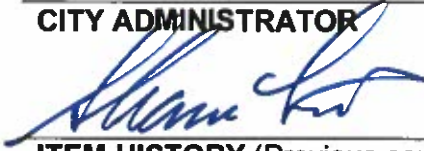

MAYOR

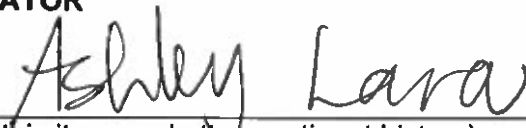

ITEM HISTORY (Previous council reviews, action related to this item, and other pertinent history)

The City of Grandview has a policy which covers the use of City credit cards to transact official City business, Chapter 27 Credit Card Use Policy of the Grandview Personnel Manual.

The credit limit for each assigned City credit card is \$1,000, the City Administrator, Police Chief and Assistant Police Chief, Fire Chief and Public Works Director is \$5,000 and the City Clerk is \$10,000, see Chapter 27.04 (A).

ITEM COMMENTARY (Background, discussion, key points, recommendations, etc.) Please identify any or all impacts this proposed action would have on the City budget, personnel resources, and/or residents.

The credit card amounts were last changed in September 2025. With changes in the department's ability to use other department cards for online purchases, the current Police Department card limits are being reached before the end of the month, and the cards are being declined by vendors. Increasing credit card limits will allow for efficient purchasing throughout the month.

ACTION PROPOSED

Move a resolution amending Section 27.04(A) of the Credit Card Use Policy within the City of Grandview Personnel Policy Manual increasing credit card limits to \$10,000 for the Police Chief, Assistant Police Chief to the March 10, 2026 regular Council meeting agenda for consideration.

Chapter 27
CREDIT CARD USE POLICY

27.04 Policy:

A. The City Council has authorized the City Administrator to implement procedures for the use of City credit cards for the following uses:

- **Travel:** Credit cards may be used by the above assigned individuals (section 2) for official business – related expenditures for hotel, parking, ferry, taxi, meals, gas, airline tickets, emergency city vehicle repairs and other travel related expenses as authorized by the Mayor or City Administrator. In addition the assigned individual may use the City credit card for conference and class registrations. Out of state travel and out of state registration require the Department Head to obtain the Mayor's pre-approval.
- **Purchases:** The assigned credit cards may be used for ordering supplies, including on-line purchases, under \$1,000 for City purposes, when pre-approved by the Department Director. The City Clerk's credit card shall be utilized for on-line purchases over \$1,000 with pre-approval by the City Clerk and City Administrator.
- **Purchases where an open charge account exists may be utilized for convenience at the time of purchase with the approval of the City Administrator.**
- **Credit Limit:** The credit limit for each assigned City credit card shall be \$1,000 for employees. The credit limit for the City Administrator, Fire Chief and Public Works Director shall be \$5,000. **The credit limit for the City Clerk, Police Chief and Assistant Police Chief shall be \$10,000.**

RESOLUTION NO. 2026-_____

**A RESOLUTION OF THE CITY OF GRANDVIEW, WASHINGTON,
AMENDING SECTION 27.04 (A) OF THE CREDIT CARD USE POLICY
WITHIN THE CITY OF GRANDVIEW PERSONNEL POLICY MANUAL
INCREASING CREDIT CARD LIMITS FOR THE POLICE CHIEF,
ASSISTANT POLICE CHIEF TO \$10,000**

WHEREAS, the City Council of the City of Grandview adopted a new Credit Card Use Policy as Chapter 27 of the Grandview Personnel Policy Manual on April 8, 2014; and

WHEREAS, the City Council desires to make certain amendments to the Credit Card Use Policy,

NOW, THEREFORE, BE IT RESOLVED BY THE CITY COUNCIL OF THE CITY OF GRANDVIEW, WASHINGTON, as follows:

Section 1: Grandview Personnel Manual Section 27.04, Policy, which reads as follows:

27.04 Policy:

A. The City Council has authorized the City Administrator to implement procedures for the use of City credit cards for the following uses:

- Travel: Credit cards may be used by the above assigned individuals (section 2) for official business – related expenditures for hotel, parking, ferry, taxi, meals, gas, airline tickets, emergency city vehicle repairs and other travel related expenses as authorized by the Mayor or City Administrator. In addition,(a) the assigned individual may use the City credit card for conference and class registrations. Out of state travel and out of state registration require the Mayor's pre-approval.
- Purchases: The assigned credit cards may be used for ordering supplies, including on-line purchases, under \$1,000 for City purposes, when pre-approved by the Department Director. The City Clerk's credit card shall be utilized for on-line purchases over \$1,000 with pre-approval by the City Clerk and City Administrator.
- Purchases where an open charge account exists may be utilized for convenience at the time of purchase with the approval of the City Administrator.

- Credit Limit: The credit limit for each assigned City credit card shall be \$1,000 for employees. The City Administrator, Police Chief, Assistant Police Chief, Fire Chief and Public Works Director's credit limit for said assigned City credit card shall be \$5,000. The City Clerk's credit limit for said assigned City credit card shall be \$10,000.
- City credit cards shall NOT be used for cash advances or personal purchases.

is hereby amended to read as follows:

27.04 Policy:

A. The City Council has authorized the City Administrator to implement procedures for the use of City credit cards for the following uses:

- Travel: Credit cards may be used by the above assigned individuals (section 2) for official business – related expenditures for hotel, parking, ferry, taxi, meals, gas, airline tickets, emergency city vehicle repairs and other travel related expenses as authorized by the Mayor or City Administrator. In addition the assigned individual may use the City credit card for conference and class registrations. Out of state travel and out of state registration require the Department Head to obtain the Mayor's pre-approval.
- Purchases: The assigned credit cards may be used for ordering supplies, including on-line purchases, under \$1,000 for City purposes, when pre-approved by the Department Director. The City Clerk's credit card shall be utilized for on-line purchases over \$1,000 with pre-approval by the City Clerk and City Administrator.
- Purchases where an open charge account exists may be utilized for convenience at the time of purchase with the approval of the City Administrator.
- Credit Limit: The credit limit for each assigned City credit card shall be \$1,000 for employees. The credit limit for the City Administrator, Fire Chief and Public Works Director shall be \$5,000. **The credit limit for the City Clerk, Police Chief and Assistant Police Chief shall be \$10,000.**

Section 2: Except as specifically amended herein, all other provisions of Chapter 27 of the Grandview Personnel Manual remain unchanged.

PASSED by the **CITY COUNCIL** and **APPROVED** by the **MAYOR** at its regular meeting on _____, 2026.

MAYOR

ATTEST:

CITY CLERK

APPROVED AS TO FORM:

CITY ATTORNEY

**CITY OF GRANDVIEW
AGENDA ITEM HISTORY/COMMENTARY
COMMITTEE-OF-THE-WHOLE MEETING**

ITEM TITLE Resolution accepting the fuel bid from Valley Wide Cooperative for the year beginning April 1, 2026 to March 31, 2027	AGENDA NO.: New Business 3 (E) AGENDA DATE: March 10, 2026
DEPARTMENT Equipment Rental	FUNDING CERTIFICATION (City Treasurer) (If applicable)

DEPARTMENT DIRECTOR REVIEW

Anita Palacios, City Clerk

CITY ADMINISTRATOR 	MAYOR 
---	--

ITEM HISTORY (Previous council reviews, action related to this item, and other pertinent history)

The City uses a common strategy of having bidders provide a bid that is compared to the Oil Information Price Service (OPIS) rack price for a specified location. The bidder is bidding their margin of markup over the rack price for the delivery location they specify. If fuel prices increase or decrease, the price is adjusted accordingly, but the margin as bid must remain the same.

ITEM COMMENTARY (Background, discussion, key points, recommendations, etc.) Please identify any or all impacts this proposed action would have on the City budget, personnel resources, and/or residents.

Bids to provide fuel for the year beginning April 1, 2026 to March 31, 2027 were opened on March 4, 2026.

Two bids were received as follows:

REGULAR UNLEADED	Valley Wide Cooperative	Christensen, Inc.
Seller's cost per gallon	\$2.9779	\$3.06818
Margin bid above seller's cost excluding taxes	\$0.14	\$0.10
TOTAL	\$3.1179	\$3.16818

DIESEL	Valley Wide Cooperative	Christensen, Inc.
Seller's cost per gallon	\$3.7983	\$3.99937
Margin bid above seller's cost excluding taxes	\$0.14	\$0.10
TOTAL	\$3.9383	\$4.09937

ACTION PROPOSED

Move a resolution accepting the fuel bid from Valley Wide Cooperative for the year beginning April 1, 2026 to March 31, 2027 to the March 10, 2026 regular Council meeting for consideration.

BID FORM

I/We the undersigned, having read all requirements of this call for bids, together with all the special provisions and specifications set forth herein, do agree in every particular, and will furnish petroleum products and documentation as specified herein as follows:

Bidder's Major Supplier is: Cenex and the OPIS price adjustment reference city shall be: ___ Seattle; ___ Spokane; ___ Moses Lake; ___ Portland; or Pasco.

	<u>Regular Unleaded</u>	<u>Diesel</u>
Estimated Annual Gallons:	<u>28,000</u>	<u>14,500</u>
Seller's Cost Per Gallon for Monday, March 2, 2026 :	<u>2.9779</u>	<u>3.7983</u>
Margin Bid Above Seller's Cost Excluding Taxes:	<u>.14</u>	<u>.14</u>
TOTAL:	<u>3.1179</u>	<u>3.9383</u>

Location(s) of 24-Hour Pumping Facilities with a **minimum number of two fueling islands**:

- 1) 940 E. Wine Country Rd, Grandview WA 98930.
- 2) 1720 Eastway Dr, Sunnyside WA, 98941
- 3) 1000 Bennett Ave, Prosser, WA 99350

Description of Method to be Used to Meet Bid Specifications B Through E: customer will be issued fuel cards to meet requirements

This bid shall be valid for a period of thirty (30) days from the bid opening date.

Bidders Name: Roman Chavez

Company Name: Valley wide Cooperative

Mail Address: 940 E. wine country rd, Grandview, WA 98930 Suite C.

Telephone Number: 509-778-2604 Fax Number: _____

Signature of Authorized Official: Roman Chavez

Title of Official: Regional Manager

**CITY OF GRANDVIEW
INSTRUCTIONS TO BIDDERS
FUEL BID**

SUBMISSION OF BIDS

Sealed bids shall be addressed or delivered to:
City Clerk
City of Grandview
207 West Second Street
Grandview, WA 98930

The bid envelope shall be clearly marked "FUEL BID."

CLOSING DATE

Bids will be received until **11:00 a.m., Wednesday, March 4, 2026.**

BID OPENING

Bids will be opened and publicly read aloud in the Council Chambers, City Hall, 207 West Second Street, Grandview, Washington, at **11:00 a.m., Wednesday, March 4, 2026**, at which time interested parties may be present to witness the bid opening.

ACCEPTABILITY OF BIDS

Bids must be submitted on the City of Grandview bid form and placed in a sealed envelope. The words "Fuel Bid" must be clearly marked on the front of the envelope.

The bid form must contain the bidders business or home address and must be signed by a duly authorized official.

Bids that are unsigned, incomplete, illegible, unbalanced, obscure, or with any other irregularities may be rejected. The City Council reserves the right to accept any or all bids or any portion thereof and to waive minor irregularities and informalities, at the City's discretion.

The bid shall be valid for thirty (30) calendar days following the bid opening date.

Prices shall be filled in where indicated on the bid form. Prices shall be net, free on board (FOB) Grandview unless otherwise stated, and shall not include any taxes, nor shall they be subject to any discounts or other conditions.

BID SPECIFICATIONS

The products shall conform to the requirements of the Tentative Specifications for Gasoline as approved by the American Society for Testing Materials, ASTM Designation D 439-81. The minimum octane rating shall conform to the Average Knock Index (R+M/2) as follows:

"Regular Unleaded" Minimum Octane 87

The seasonal variation in volatility and vapor pressure shall be substantially maintained in accordance with the schedule set up for the State of Washington as set forth in ASTM specifications above noted.

Bidders shall give the following information relative to each grade of gasoline bid in the spaces provided:

1. The name of the brand under which the gasoline is offered for sale to the general public:

"Regular Unleaded" gasoline: Cenex

"Diesel": Cenex

2. The nature of any added substances other than volatile petroleum hydrocarbons.

"Regular Unleaded" gasoline:

3. The guaranteed average and minimum Octane Number for "Regular Unleaded" grade:

"Regular Unleaded" Average 87 Minimum 87

4. The guaranteed average and maximum Sulphur Content in "Diesel"

Grade No. 2 : Average less than 15 ppm Minimum less than 15 ppm

All bids shall be made for a card controlled fuel purchase system for regular gasoline, unleaded gasoline, and diesel fuel. Ease of City staff operation and accounting time for this system will be taken into consideration when determining the low bid.

- A. There must be a "card lock" pumping location in the City of Grandview with 24 hour service and a **minimum number of two fueling islands**.
- B. At the time of purchase, the vehicle, person obtaining fuel, and odometer reading must be identified and recorded by the supplier.
- C. The supplier shall furnish two numbered cards for each vehicle. There are approximately 70 vehicles.
- D. The supplier shall provide security codes for all City vehicle operators, to be used in conjunction with the vehicle cards for purchases of fuel. There are approximately 60 employees.
- E. The supplier must provide a monthly accounting that must include an itemized account detailing the activity of each vehicle. This accounting as a minimum must sub-total by vehicle and list: date, time, vehicle card number, person obtaining fuel, odometer reading, type of fuel, gallons and actual price charged. Each monthly billing shall also include copies of the appropriate weekly OPIS publication for that billing cycle or the major supplier's price change letter.

PRICING, PRICE ESCALATION - BULK FUELS

- A. Contract prices will be allowed to increase or decrease after bid opening and during the term of the contract. All contract price adjustments shall be based on the change in the vendor's major supplier's listed price for one of the following P.A.D cities: Seattle, Spokane, Portland, Moses Lake, or Pasco as reported in the weekly publications, Oil Price Information Service (OPIS) published by the United Communications Group. A second method shall be to reference the major supplier's price change letter which reflects changes at the location of your plant.
- B. Bidder shall specify his supplier (See Requirements and the Bid Proposal) and the price adjustment reference city (Seattle, Spokane, Portland, Moses Lake, or Pasco) to be used for contract price adjustments on the Bid Proposal. **Only one supplier and one reference city may be specified by each bidder. A copy of the appropriate OPIS publication, or in the case of the second method (above) the calculation price shall be your buying price per gallon with Federal and State taxes excluded, used as a bidding reference and must be included with the bid submitted.** If OPIS does not list one or more supplier product prices for a reference city, the listed average price for that city shall be used.
- C. Any upward or downward change in the major supplier's prices from one OPIS publication to the next, or change in the price from the major supplier's price change letter will be added or subtracted from the previous contract price but the margin as bid will remain the same. It is important to note that the difference between the Bid Price and the selected OPIS Price or major suppliers price change letter at the time of the bid, must be maintained throughout the period of the contract. The effective date of the price change will be on Thursday following the date of the publication which reflects the price change.
- D. The first price adjustment shall be based on the difference in the prices for the last OPIS publication issue or major supplier's price change letter prior to the effective date of the contract. Any upward or downward change in the comparison of prices will be added to or subtracted from bid prices with the effective date of such change to be the **first of April 2026** rather than the following Thursday.

BIDDERS QUALIFICATIONS

Bidders may be required to submit evidence as to their ability to supply and provide the above defined service and should be prepared to satisfy the City as to their competency to meet the specifications and conditions. Bidders, when required by law, shall be licensed and bonded by the State of Washington.

CONDITIONS

The bidder is fully responsible for obtaining all information for the preparation of this bid.

LIABILITY

The bidder shall ensure that the City, it's officers and employees, are held harmless from any liability whatsoever arising out of the bidder's performance or non-performance of the term of this bid, including the performance and non-performance by any sub-contractor or employee.

CONTRACTORS PROTECTIVE CLAUSE

There shall be no obligation to deliver any or all of the products included in this proposal in the customary manner when such deliveries are prevented or hindered by Act of God, fire, strike, partial or total interruptions or loss or shortage of transportation facilities, or by other similar or different acts of civil or military authorities, or by other like causes beyond the control of the contractor.

FURTHER INFORMATION

Contact Anita Palacios, City Clerk, 207 West Second Street, Grandview, Washington, 98930, or PH: (509) 882-9200, email anitap@grandview.wa.us.

CHS Refined Fuels Rack Price Notification

Rack Pricing For: VALLEY WIDE COOPERATIVE INC

MT MISSOULA-CNX/RF/AD Effective: 03/02/2026 18:00

Product-Branded	Change	Price	Product-Branded	Change	Price
ULSD15 #1 CLEAR	+0.1768	3.3080	ULSD15 #1 DYED	+0.1767	3.3120
ULSD15 #2 CLEAR	+0.1767	2.8231	ULSD15 #2 DYED	+0.1768	2.8272
CENEX® ROADMASTER XL	+0.1768	2.8706	CENEX® RUBY FIELDMASTER	+0.1768	2.8747
CENEX® WINTERMASTER CLEAR	+0.1768	3.2205	CENEX® WINTERMASTER DYED	+0.1768	3.2246
ULSD15 #2 CLEAR WA IV	+0.1767	2.8381	CENEX® RUBY FIELDMASTER SE	+0.1768	3.0275
CENEX® ROADMASTER XL SE	+0.1768	3.0234	ULSD15 #2 DYED WA IV	+0.1768	2.8422
CENEX® RUBY FIELDMASTER WA IV	+0.1768	2.8897	CENEX® ROADMASTER XL WA IV	+0.1768	2.8856
UNLEADED 87 10% ETH	+0.1218	2.2951	UNLEADED 89 3-WAY 10% ETH	+0.1193	2.5335
UNLEADED 91 3-WAY 10% ETH	+0.1217	2.7688	UNLEADED 93 10% ETH	+0.1216	2.9708
UNLEADED 91	+0.1215	3.0511			

MT LOGAN-CNX/RF/AD Effective: 03/02/2026 18:00

Product-Branded	Change	Price	Product-Branded	Change	Price
ULSD15 #1 CLEAR	+0.1805	3.3848	ULSD15 #1 DYED	+0.1804	3.3888
ULSD15 #2 CLEAR	+0.1804	2.8797	ULSD15 #2 DYED	+0.1804	2.8837
CENEX® ROADMASTER XL	+0.1804	2.9272	CENEX® RUBY FIELDMASTER	+0.1804	2.9312
CENEX® WINTERMASTER CLEAR	+0.1804	3.2912	CENEX® WINTERMASTER DYED	+0.1804	3.2953
ULSD15 #2 CLEAR WA IV	+0.1804	2.8947	CENEX® RUBY FIELDMASTER SE	+0.1804	3.0932
CENEX® ROADMASTER XL SE	+0.1804	3.0892	#1 CENEX® RUBY FIELDMASTER	+0.1804	3.4363
#1 CENEX® ROADMASTER XL	+0.1804	3.4322	ULSD15 #2 DYED WA IV	+0.1804	2.8987
CENEX® RUBY FIELDMASTER WA IV	+0.1804	2.9462	CENEX® ROADMASTER XL WA IV	+0.1804	2.9422
UNLEADED 87 10% ETH	+0.1229	2.3160	UNLEADED 89 3-WAY 10% ETH	+0.1209	2.5574
UNLEADED 91 3-WAY 10% ETH	+0.1226	2.7897	UNLEADED 93 10% ETH	+0.1227	2.9918
UNLEADED 91	+0.1215	3.0676			

WA HILLYARD-HFT/RF/AD Effective: 03/02/2026 18:00

Product-Branded	Change	Price	Product-Branded	Change	Price
ULSD15 #1 CLEAR	+0.1520	4.4720	ULSD15 #1 DYED	+0.1519	4.4760
ULSD15 #2 CLEAR	+0.1343	3.7281	ULSD15 #2 DYED	+0.1343	3.7321
CENEX® ROADMASTER XL	+0.1343	3.7755	CENEX® RUBY FIELDMASTER	+0.1343	3.7796
CENEX® ROADMASTER XL CFI	+0.1343	3.8005	UNLEADED 92 10% ETH	+0.0906	3.2853
ULSD15 #2 CLEAR CFI	+0.1343	3.7531	ULSD15 #2 DYED CFI	+0.1343	3.7571
CENEX® RUBY FIELDMASTER CFI	+0.1343	3.8046	UNLEADED 87 10% ETH	+0.0724	2.8630
UNLEADED 89 3-WAY 10% ETH	+0.0888	3.1071			

WA PASCO-TWB/RF Effective: 03/02/2026 18:00

Product-Branded	Change	Price	Product-Branded	Change	Price
ETHANOL E85	+0.0982	2.3719	ULSD15 #1 CLEAR	+0.1353	4.3033
ULSD15 #1 DYED	+0.1354	4.3074	ULSD15 #2 CLEAR	+0.1354	3.7983
ULSD15 #2 DYED	+0.1353	3.8023	CENEX® ROADMASTER XL	+0.1354	3.8458
CENEX® RUBY FIELDMASTER	+0.1354	3.8498	CENEX® ROADMASTER XL CFI	+0.1354	3.8658
ULSD15 #2 CLEAR B5	+0.1440	3.8388	CENEX® RUBY FIELDMASTER B5 CFI	+0.1440	3.9103
CENEX® RUBY FIELDMASTER B20	+0.1451	3.8334	CENEX® ROADMASTER XL B20	+0.1451	3.8294
ULSD15 #2 CLEAR B20	+0.1451	3.7819	UNLEADED 92 10% ETH	+0.0980	3.3443
CENEX® ROADMASTER XL B5	+0.1440	3.8863	CENEX® RUBY FIELDMASTER B5	+0.1440	3.8903
ULSD15 #2 CLEAR CFI	+0.1354	3.8183	ETHANOL	+0.1212	1.9697
ULSD15 #2 DYED CFI	+0.1353	3.8223	CENEX® ROADMASTER XL B5 CFI	+0.1440	3.9063
ULSD15 #2 DYED B5	+0.1439	3.8428	ULSD15 #2 DYED B20	+0.1451	3.7859
CENEX® RUBY FIELDMASTER CFI	+0.1354	3.8698	UNLEADED 87 10% ETH	+0.0982	2.9779

UNLEADED 89 10% ETH +0.0956 3.2276

MT BOZEMAN-P66/RF Effective: 03/02/2026 18:00

Product-Branded	Change	Price	Product-Branded	Change	Price
ULSD15 #1 CLEAR	+0.1805	3.3848	ULSD15 #1 DYED	+0.1804	3.3888
ULSD15 #2 CLEAR	+0.1804	2.8797	ULSD15 #2 DYED	+0.1804	2.8837
ULSD15 #2 CLEAR CFI	+0.1804	2.8947	ULSD15 #2 DYED CFI	+0.1804	2.8987
UNLEADED 87 10% ETH	+0.1229	2.3160	UNLEADED 91 3-WAY 10% ETH	+0.1226	2.7897
UNLEADED 91	+0.1215	3.0676			

WA MOSES LAKE-P66/RF Effective: 03/02/2026 18:00

Product-Branded	Change	Price	Product-Branded	Change	Price
ULSD15 #2 CLEAR	+0.1274	3.7055	ULSD15 #2 DYED	+0.1275	3.7096
UNLEADED 89 10% ETH LAC	+0.0858	3.0617	ULSD15 #2 CLEAR CFI	+0.1274	3.7355
ULSD15 #2 DYED CFI	+0.1275	3.7396	UNLEADED 87 10% ETH LAC	+0.0857	2.8293
UNLEADED 91 LAC	+0.0857	3.6576	UNLEADED 92 10% ETH LAC	+0.0858	3.2940

OR UMATILLA-TWB/RF Effective: 03/02/2026 18:00

Product-Branded	Change	Price	Product-Branded	Change	Price
ULSD15 #1 CLEAR	+0.1451	4.0008	ULSD15 #1 DYED	+0.1451	4.0048
ULSD15 #2 CLEAR B5	+0.1403	3.3042	ULSD15 #2 CLEAR B20	+0.1403	3.3042
ULSD15 #2 DYED B5	+0.1404	3.3083	ULSD15 #2 DYED B20	+0.1404	3.3083

WA SEATTLE-BP/RF Effective: 03/02/2026 18:00

Product-Branded	Change	Price	Product-Branded	Change	Price
ULSD15 #1 CLEAR	+0.1386	4.2601	ULSD15 #1 DYED	+0.1387	4.2642
ULSD15 #2 CLEAR	+0.1387	3.7046	ULSD15 #2 DYED	+0.1386	3.7086
ULSD15 #2 CLEAR B20	+0.1312	4.0430	UNLEADED 92 10% ETH	+0.1012	3.4436
ULSD15 #2 DYED B20	+0.1312	4.0471	UNLEADED 87 10% ETH	+0.0892	3.0916
UNLEADED 87 BLEND CLEAR	+0.0897	3.4127	UNLEADED 89 3-WAY 10% ETH	+0.1021	3.3052

WA TACOMA-PAR/RF/PR Effective: 03/02/2026 18:00

Product-Branded	Change	Price	Product-Branded	Change	Price
ULSD15 #2 CLEAR	+0.1394	3.7656	ULSD15 #2 DYED	+0.1394	3.7697
CENEX® ROADMASTER XL	+0.1394	3.8131	CENEX® RUBY FIELDMASTER	+0.1394	3.8171
UNLEADED PREMIUM BLEND GRADE 10% ETH	+0.0838	3.4818	UNLEADED 89	+0.0981	3.7876
UNLEADED 92	+0.1058	4.4737	UNLEADED 87 10% ETH	+0.0982	3.0877
UNLEADED 87 BLEND CLEAR	+0.0981	3.7671	UNLEADED 89 3-WAY 10% ETH	+0.0837	3.3291

BID FORM

I/We the undersigned, having read all requirements of this call for bids, together with all the special provisions and specifications set forth herein, do agree in every particular, and will furnish petroleum products and documentation as specified herein as follows:

Bidder's Major Supplier is: Unbranded and the OPIS price adjustment reference city shall be: ___ Seattle; ___ Spokane; ___ Moses Lake; ___ Portland; or
X Pasco.

Estimated Annual Gallons:	<u>Regular Unleaded</u> 28,000	<u>Diesel</u> 14,500
Seller's Cost Per Gallon for Monday, March 2, 2026:	<u>3.06818</u>	<u>3.99937</u>
Margin Bid Above Seller's Cost Excluding Taxes:	<u>.10</u>	<u>.10</u>
TOTAL:	<u>3.16818</u>	<u>4.09937</u>

Location(s) of 24-Hour Pumping Facilities with a minimum number of two fueling islands:
940 East Wine Country Rd. Grandview WA, 98930

Description of Method to be Used to Meet Bid Specifications B Through E: We will issue vehicle cards via CFN with associated Driver pins that with each invoice will identify the vehicle, driver, and odometer reading. This information is also available in the customer portal. Christensen can provide two cards for each vehicle, floating pin will allow any driver to use any card and any vehicle and still be identified. Christensen standard invoice and reports available in Christensen customer portal covers all aspects of E. This bid shall be valid for a period of thirty (30) days from the bid opening date.

Bidders Name: Keagan Christensen

Company Name: Christensen, Inc.

Mail Address: 1060 Jadwin Ave. Richland WA. 99352

Telephone Number: (888)266-3030 Fax Number: _____

Signature of Authorized Official: Keagan Christensen

Title of Official: Owner, Sales Manager

**CITY OF GRANDVIEW
INSTRUCTIONS TO BIDDERS
FUEL BID**

SUBMISSION OF BIDS

Sealed bids shall be addressed or delivered to:

City Clerk
City of Grandview
207 West Second Street
Grandview, WA 98930

The bid envelope shall be clearly marked "FUEL BID."

CLOSING DATE

Bids will be received until **11:00 a.m., Wednesday, March 4, 2026.**

BID OPENING

Bids will be opened and publicly read aloud in the Council Chambers, City Hall, 207 West Second Street, Grandview, Washington, at **11:00 a.m., Wednesday, March 4, 2026**, at which time interested parties may be present to witness the bid opening.

ACCEPTABILITY OF BIDS

Bids must be submitted on the City of Grandview bid form and placed in a sealed envelope. The words "Fuel Bid" must be clearly marked on the front of the envelope.

The bid form must contain the bidders business or home address and must be signed by a duly authorized official.

Bids that are unsigned, incomplete, illegible, unbalanced, obscure, or with any other irregularities may be rejected. The City Council reserves the right to accept any or all bids or any portion thereof and to waive minor irregularities and informalities, at the City's discretion.

The bid shall be valid for thirty (30) calendar days following the bid opening date.

Prices shall be filled in where indicated on the bid form. Prices shall be net, free on board (FOB) Grandview unless otherwise stated, and shall not include any taxes, nor shall they be subject to any discounts or other conditions.

BID SPECIFICATIONS

The products shall conform to the requirements of the Tentative Specifications for Gasoline as approved by the American Society for Testing Materials, ASTM Designation D 439-81. The minimum octane rating shall conform to the Average Knock Index (R+M/2) as follows:

"Regular Unleaded" Minimum Octane 87

The seasonal variation in volatility and vapor pressure shall be substantially maintained in accordance with the schedule set up for the State of Washington as set forth in ASTM specifications above noted.

Bidders shall give the following information relative to each grade of gasoline bid in the spaces provided:

1. The name of the brand under which the gasoline is offered for sale to the general public:
"Regular Unleaded" gasoline: Marathon
"Diesel": Unbranded
2. The nature of any added substances other than volatile petroleum hydrocarbons.
"Regular Unleaded" gasoline:
3. The guaranteed average and minimum Octane Number for "Regular Unleaded" grade:
"Regular Unleaded" Average 87 Minimum 87
4. The guaranteed average and maximum Sulphur Content in "Diesel"
Grade No. 2: Average 10 PPM Minimum 7 PPM

All bids shall be made for a card controlled fuel purchase system for regular gasoline, unleaded gasoline, and diesel fuel. Ease of City staff operation and accounting time for this system will be taken into consideration when determining the low bid.

- A. There must be a "card lock" pumping location in the City of Grandview with 24 hour service and a **minimum number of two fueling islands**.
- B. At the time of purchase, the vehicle, person obtaining fuel, and odometer reading must be identified and recorded by the supplier.
- C. The supplier shall furnish two numbered cards for each vehicle. There are approximately 70 vehicles.
- D. The supplier shall provide security codes for all City vehicle operators, to be used in conjunction with the vehicle cards for purchases of fuel. There are approximately 60 employees.
- E. The supplier must provide a monthly accounting that must include an itemized account detailing the activity of each vehicle. This accounting as a minimum must sub-total by vehicle and list: date, time, vehicle card number, person obtaining fuel, odometer reading, type of fuel, gallons and actual price charged. Each monthly billing shall also include copies of the appropriate weekly OPIS publication for that billing cycle or the major supplier's price change letter.

PRICING, PRICE ESCALATION - BULK FUELS

- A. Contract prices will be allowed to increase or decrease after bid opening and during the term of the contract. All contract price adjustments shall be based on the change in the vendor's major supplier's listed price for one of the following P.A.D cities: Seattle, Spokane, Portland, Moses Lake, or Pasco as reported in the weekly publications, Oil Price Information Service (OPIS) published by the United Communications Group. A second method shall be to reference the major supplier's price change letter which reflects changes at the location of your plant.
- B. Bidder shall specify his supplier (See Requirements and the Bid Proposal) and the price adjustment reference city (Seattle, Spokane, Portland, Moses Lake, or Pasco) to be used for contract price adjustments on the Bid Proposal. Only one supplier and one reference city may be specified by each bidder. **A copy of the appropriate OPIS publication, or in the case of the second method (above) the calculation price shall be your buying price per gallon with Federal and State taxes excluded, used as a bidding reference and must be included with the bid submitted.** If OPIS does not list one or more supplier product prices for a reference city, the listed average price for that city shall be used.
- C. Any upward or downward change in the major supplier's prices from one OPIS publication to the next, or change in the price from the major supplier's price change letter will be added or subtracted from the previous contract price but the margin as bid will remain the same. It is important to note that the difference between the Bid Price and the selected OPIS Price or major suppliers price change letter at the time of the bid, must be maintained throughout the period of the contract. The effective date of the price change will be on Thursday following the date of the publication which reflects the price change.
- D. The first price adjustment shall be based on the difference in the prices for the last OPIS publication issue or major supplier's price change letter prior to the effective date of the contract. Any upward or downward change in the comparison of prices will be added to or subtracted from bid prices with the effective date of such change to be the **first of April 2026** rather than the following Thursday.

BIDDERS QUALIFICATIONS

Bidders may be required to submit evidence as to their ability to supply and provide the above defined service and should be prepared to satisfy the City as to their competency to meet the specifications and conditions. Bidders, when required by law, shall be licensed and bonded by the State of Washington.

CONDITIONS

The bidder is fully responsible for obtaining all information for the preparation of this bid.

LIABILITY

The bidder shall ensure that the City, it's officers and employees, are held harmless from any liability whatsoever arising out of the bidder's performance or non-performance of the term of this bid, including the performance and non-performance by any sub-contractor or employee.

CONTRACTORS PROTECTIVE CLAUSE

There shall be no obligation to deliver any or all of the products included in this proposal in the customary manner when such deliveries are prevented or hindered by Act of God, fire, strike, partial or total interruptions or loss or shortage of transportation facilities, or by other similar or different acts of civil or military authorities, or by other like causes beyond the control of the contractor.

FURTHER INFORMATION

Contact Anita Palacios, City Clerk, 207 West Second Street, Grandview, Washington, 98930, or PH: (509) 882-9200, email anitap@grandview.wa.us.

RESOLUTION NO. 2026-_____

**A RESOLUTION OF THE CITY OF GRANDVIEW, WASHINGTON,
ACCEPTING THE FUEL BID FROM VALLEY WIDE COOPERATIVE FOR THE
YEAR BEGINNING APRIL 1, 2026 TO MARCH 31, 2027**

WHEREAS, the City has solicited bids from qualified fuel companies to provide vehicle fuel to the City of Grandview for the year beginning April 1, 2026 to March 31, 2027; and,

WHEREAS, the City received two (2) bids in response to such solicitation; and,

WHEREAS, the City Council finds and determines that Valley Wide Cooperative is the lowest responsible bidder;

NOW, THEREFORE, BE IT RESOLVED BY THE CITY COUNCIL OF THE CITY OF GRANDVIEW, WASHINGTON, as follows:

That the bid submitted by the Valley Wide Cooperative, as set forth in the attached bid, is hereby approved and accepted, and the Mayor is hereby authorized to execute any and all documents necessary or appropriate to accomplish such transaction.

PASSED by the **CITY COUNCIL** and **APPROVED** by the **MAYOR** at its regular meeting on _____, 2026.

MAYOR

ATTEST:

CITY CLERK

APPROVED AS TO FORM:

CITY ATTORNEY

BID FORM

I/We the undersigned, having read all requirements of this call for bids, together with all the special provisions and specifications set forth herein, do agree in every particular, and will furnish petroleum products and documentation as specified herein as follows:

Bidder's Major Supplier is: Cenex and the OPIS price adjustment reference city shall be: ___ Seattle; ___ Spokane; ___ Moses Lake; ___ Portland; or Pasco.

	<u>Regular Unleaded</u>	<u>Diesel</u>
Estimated Annual Gallons:	<u>28,000</u>	<u>14,500</u>
Seller's Cost Per Gallon for Monday, March 2, 2026 :	<u>2.9779</u>	<u>3.7983</u>
Margin Bid Above Seller's Cost Excluding Taxes:	<u>.14</u>	<u>.14</u>
TOTAL:	<u>3.1179</u>	<u>3.9383</u>

Location(s) of 24-Hour Pumping Facilities with a minimum number of two fueling islands:

- 1) 940 E. Wine Country Rd, Grandview WA 98930. 2) 1720 Eastway Dr, Sunnyside WA, 98944
3) 1000 Bennett Ave, Prosser, WA 99350

Description of Method to be Used to Meet Bid Specifications B Through E: Customer will be issued fuel cards to meet requirements

This bid shall be valid for a period of thirty (30) days from the bid opening date.

Bidders Name: Roman Chavez

Company Name: Valley Wide Cooperative

Mail Address: 940 E. Wine Country Rd, Grandview, WA 98930 Suite C.

Telephone Number: 509-778-2604 Fax Number: _____

Signature of Authorized Official: Roman Chavez

Title of Official: Regional Manager

**CITY OF GRANDVIEW
INSTRUCTIONS TO BIDDERS
FUEL BID**

SUBMISSION OF BIDS

Sealed bids shall be addressed or delivered to:
City Clerk
City of Grandview
207 West Second Street
Grandview, WA 98930

The bid envelope shall be clearly marked "FUEL BID."

CLOSING DATE

Bids will be received until **11:00 a.m., Wednesday, March 4, 2026.**

BID OPENING

Bids will be opened and publicly read aloud in the Council Chambers, City Hall, 207 West Second Street, Grandview, Washington, at **11:00 a.m., Wednesday, March 4, 2026**, at which time interested parties may be present to witness the bid opening.

ACCEPTABILITY OF BIDS

Bids must be submitted on the City of Grandview bid form and placed in a sealed envelope. The words "Fuel Bid" must be clearly marked on the front of the envelope.

The bid form must contain the bidders business or home address and must be signed by a duly authorized official.

Bids that are unsigned, incomplete, illegible, unbalanced, obscure, or with any other irregularities may be rejected. The City Council reserves the right to accept any or all bids or any portion thereof and to waive minor irregularities and informalities, at the City's discretion.

The bid shall be valid for thirty (30) calendar days following the bid opening date.

Prices shall be filled in where indicated on the bid form. Prices shall be net, free on board (FOB) Grandview unless otherwise stated, and shall not include any taxes, nor shall they be subject to any discounts or other conditions.

BID SPECIFICATIONS

The products shall conform to the requirements of the Tentative Specifications for Gasoline as approved by the American Society for Testing Materials, ASTM Designation D 439-81. The minimum octane rating shall conform to the Average Knock Index (R+M/2) as follows:

"Regular Unleaded" Minimum Octane 87

The seasonal variation in volatility and vapor pressure shall be substantially maintained in accordance with the schedule set up for the State of Washington as set forth in ASTM specifications above noted.

Bidders shall give the following information relative to each grade of gasoline bid in the spaces provided:

1. The name of the brand under which the gasoline is offered for sale to the general public:

"Regular Unleaded" gasoline: Cenex

"Diesel": Cenex

2. The nature of any added substances other than volatile petroleum hydrocarbons.

"Regular Unleaded" gasoline:

3. The guaranteed average and minimum Octane Number for "Regular Unleaded" grade:

"Regular Unleaded" Average 87 Minimum 87

4. The guaranteed average and maximum Sulphur Content in "Diesel"

Grade No. 2 : Average less than 15 ppm Minimum less than 15 ppm

All bids shall be made for a card controlled fuel purchase system for regular gasoline, unleaded gasoline, and diesel fuel. Ease of City staff operation and accounting time for this system will be taken into consideration when determining the low bid.

- A. There must be a "card lock" pumping location in the City of Grandview with 24 hour service and a **minimum number of two fueling islands**.
- B. At the time of purchase, the vehicle, person obtaining fuel, and odometer reading must be identified and recorded by the supplier.
- C. The supplier shall furnish two numbered cards for each vehicle. There are approximately 70 vehicles.
- D. The supplier shall provide security codes for all City vehicle operators, to be used in conjunction with the vehicle cards for purchases of fuel. There are approximately 60 employees.
- E. The supplier must provide a monthly accounting that must include an itemized account detailing the activity of each vehicle. This accounting as a minimum must sub-total by vehicle and list: date, time, vehicle card number, person obtaining fuel, odometer reading, type of fuel, gallons and actual price charged. Each monthly billing shall also include copies of the appropriate weekly OPIS publication for that billing cycle or the major supplier's price change letter.

PRICING, PRICE ESCALATION - BULK FUELS

- A. Contract prices will be allowed to increase or decrease after bid opening and during the term of the contract. All contract price adjustments shall be based on the change in the vendor's major supplier's listed price for one of the following P.A.D cities: Seattle, Spokane, Portland, Moses Lake, or Pasco as reported in the weekly publications, Oil Price Information Service (OPIS) published by the United Communications Group. A second method shall be to reference the major supplier's price change letter which reflects changes at the location of your plant.
- B. Bidder shall specify his supplier (See Requirements and the Bid Proposal) and the price adjustment reference city (Seattle, Spokane, Portland, Moses Lake, or Pasco) to be used for contract price adjustments on the Bid Proposal. Only one supplier and one reference city may be specified by each bidder. A copy of the appropriate OPIS publication, or in the case of the second method (above) the calculation price shall be your buying price per gallon with Federal and State taxes excluded, used as a bidding reference and **must** be included with the bid submitted. If OPIS does not list one or more supplier product prices for a reference city, the listed average price for that city shall be used.
- C. Any upward or downward change in the major supplier's prices from one OPIS publication to the next, or change in the price from the major supplier's price change letter will be added or subtracted from the previous contract price but the margin as bid will remain the same. It is important to note that the difference between the Bid Price and the selected OPIS Price or major suppliers price change letter at the time of the bid, must be maintained throughout the period of the contract. The effective date of the price change will be on Thursday following the date of the publication which reflects the price change.
- D. The first price adjustment shall be based on the difference in the prices for the last OPIS publication issue or major supplier's price change letter prior to the effective date of the contract. Any upward or downward change in the comparison of prices will be added to or subtracted from bid prices with the effective date of such change to be the **first of April 2026** rather than the following Thursday.

BIDDERS QUALIFICATIONS

Bidders may be required to submit evidence as to their ability to supply and provide the above defined service and should be prepared to satisfy the City as to their competency to meet the specifications and conditions. Bidders, when required by law, shall be licensed and bonded by the State of Washington.

CONDITIONS

The bidder is fully responsible for obtaining all information for the preparation of this bid.

LIABILITY

The bidder shall ensure that the City, it's officers and employees, are held harmless from any liability whatsoever arising out of the bidder's performance or non-performance of the term of this bid, including the performance and non-performance by any sub-contractor or employee.

CONTRACTORS PROTECTIVE CLAUSE

There shall be no obligation to deliver any or all of the products included in this proposal in the customary manner when such deliveries are prevented or hindered by Act of God, fire, strike, partial or total interruptions or loss or shortage of transportation facilities, or by other similar or different acts of civil or military authorities, or by other like causes beyond the control of the contractor.

FURTHER INFORMATION

Contact Anita Palacios, City Clerk, 207 West Second Street, Grandview, Washington, 98930, or PH: (509) 882-9200, email anitap@grandview.wa.us.

CHS Refined Fuels Rack Price Notification

Rack Pricing For: VALLEY WIDE COOPERATIVE INC

MT MISSOULA-CNX/RF/AD Effective: 03/02/2026 18:00

Product-Branded	Change	Price	Product-Branded	Change	Price
ULSD15 #1 CLEAR	+0.1768	3.3080	ULSD15 #1 DYED	+0.1767	3.3120
ULSD15 #2 CLEAR	+0.1767	2.8231	ULSD15 #2 DYED	+0.1768	2.8272
CENEX® ROADMASTER XL	+0.1768	2.8706	CENEX® RUBY FIELDMASTER	+0.1768	2.8747
CENEX® WINTERMASTER CLEAR	+0.1768	3.2205	CENEX® WINTERMASTER DYED	+0.1768	3.2246
ULSD15 #2 CLEAR WA IV	+0.1767	2.8381	CENEX® RUBY FIELDMASTER SE	+0.1768	3.0275
CENEX® ROADMASTER XL SE	+0.1768	3.0234	ULSD15 #2 DYED WA IV	+0.1768	2.8422
CENEX® RUBY FIELDMASTER WA IV	+0.1768	2.8897	CENEX® ROADMASTER XL WA IV	+0.1768	2.8856
UNLEADED 87 10% ETH	+0.1218	2.2951	UNLEADED 89 3-WAY 10% ETH	+0.1193	2.5335
UNLEADED 91 3-WAY 10% ETH	+0.1217	2.7688	UNLEADED 93 10% ETH	+0.1216	2.9708
UNLEADED 91	+0.1215	3.0511			

MT LOGAN-CNX/RF/AD Effective: 03/02/2026 18:00

Product-Branded	Change	Price	Product-Branded	Change	Price
ULSD15 #1 CLEAR	+0.1805	3.3848	ULSD15 #1 DYED	+0.1804	3.3888
ULSD15 #2 CLEAR	+0.1804	2.8797	ULSD15 #2 DYED	+0.1804	2.8837
CENEX® ROADMASTER XL	+0.1804	2.9272	CENEX® RUBY FIELDMASTER	+0.1804	2.9312
CENEX® WINTERMASTER CLEAR	+0.1804	3.2912	CENEX® WINTERMASTER DYED	+0.1804	3.2953
ULSD15 #2 CLEAR WA IV	+0.1804	2.8947	CENEX® RUBY FIELDMASTER SE	+0.1804	3.0932
CENEX® ROADMASTER XL SE	+0.1804	3.0892	#1 CENEX® RUBY FIELDMASTER	+0.1804	3.4363
#1 CENEX® ROADMASTER XL	+0.1804	3.4322	ULSD15 #2 DYED WA IV	+0.1804	2.8987
CENEX® RUBY FIELDMASTER WA IV	+0.1804	2.9462	CENEX® ROADMASTER XL WA IV	+0.1804	2.9422
UNLEADED 87 10% ETH	+0.1229	2.3160	UNLEADED 89 3-WAY 10% ETH	+0.1209	2.5574
UNLEADED 91 3-WAY 10% ETH	+0.1226	2.7897	UNLEADED 93 10% ETH	+0.1227	2.9918
UNLEADED 91	+0.1215	3.0676			

WA HILLYARD-HFT/RF/AD Effective: 03/02/2026 18:00

Product-Branded	Change	Price	Product-Branded	Change	Price
ULSD15 #1 CLEAR	+0.1520	4.4720	ULSD15 #1 DYED	+0.1519	4.4760
ULSD15 #2 CLEAR	+0.1343	3.7281	ULSD15 #2 DYED	+0.1343	3.7321
CENEX® ROADMASTER XL	+0.1343	3.7755	CENEX® RUBY FIELDMASTER	+0.1343	3.7796
CENEX® ROADMASTER XL CFI	+0.1343	3.8005	UNLEADED 92 10% ETH	+0.0906	3.2853
ULSD15 #2 CLEAR CFI	+0.1343	3.7531	ULSD15 #2 DYED CFI	+0.1343	3.7571
CENEX® RUBY FIELDMASTER CFI	+0.1343	3.8046	UNLEADED 87 10% ETH	+0.0724	2.8630
UNLEADED 89 3-WAY 10% ETH	+0.0888	3.1071			

WA PASCO-TWB/RF Effective: 03/02/2026 18:00

Product-Branded	Change	Price	Product-Branded	Change	Price
ETHANOL E85	+0.0982	2.3719	ULSD15 #1 CLEAR	+0.1353	4.3033
ULSD15 #1 DYED	+0.1354	4.3074	ULSD15 #2 CLEAR	+0.1354	3.7983
ULSD15 #2 DYED	+0.1353	3.8023	CENEX® ROADMASTER XL	+0.1354	3.8458
CENEX® RUBY FIELDMASTER	+0.1354	3.8498	CENEX® ROADMASTER XL CFI	+0.1354	3.8658
ULSD15 #2 CLEAR B5	+0.1440	3.8388	CENEX® RUBY FIELDMASTER B5 CFI	+0.1440	3.9103
CENEX® RUBY FIELDMASTER B20	+0.1451	3.8334	CENEX® ROADMASTER XL B20	+0.1451	3.8294
ULSD15 #2 CLEAR B20	+0.1451	3.7819	UNLEADED 92 10% ETH	+0.0980	3.3443
CENEX® ROADMASTER XL B5	+0.1440	3.8863	CENEX® RUBY FIELDMASTER B5	+0.1440	3.8903
ULSD15 #2 CLEAR CFI	+0.1354	3.8183	ETHANOL	+0.1212	1.9697
ULSD15 #2 DYED CFI	+0.1353	3.8223	CENEX® ROADMASTER XL B5 CFI	+0.1440	3.9063
ULSD15 #2 DYED B5	+0.1439	3.8428	ULSD15 #2 DYED B20	+0.1451	3.7859
CENEX® RUBY FIELDMASTER CFI	+0.1354	3.8698	UNLEADED 87 10% ETH	+0.0982	2.9779

UNLEADED 89 10% ETH +0.0956 3.2276

MT BOZEMAN-P66/RF Effective: 03/02/2026 18:00

Product-Branded	Change	Price	Product-Branded	Change	Price
ULSD15 #1 CLEAR	+0.1805	3.3848	ULSD15 #1 DYED	+0.1804	3.3888
ULSD15 #2 CLEAR	+0.1804	2.8797	ULSD15 #2 DYED	+0.1804	2.8837
ULSD15 #2 CLEAR CFI	+0.1804	2.8947	ULSD15 #2 DYED CFI	+0.1804	2.8987
UNLEADED 87 10% ETH	+0.1229	2.3160	UNLEADED 91 3-WAY 10% ETH	+0.1226	2.7897
UNLEADED 91	+0.1215	3.0676			

WA MOSES LAKE-P66/RF Effective: 03/02/2026 18:00

Product-Branded	Change	Price	Product-Branded	Change	Price
ULSD15 #2 CLEAR	+0.1274	3.7055	ULSD15 #2 DYED	+0.1275	3.7096
UNLEADED 89 10% ETH LAC	+0.0858	3.0617	ULSD15 #2 CLEAR CFI	+0.1274	3.7355
ULSD15 #2 DYED CFI	+0.1275	3.7396	UNLEADED 87 10% ETH LAC	+0.0857	2.8293
UNLEADED 91 LAC	+0.0857	3.6576	UNLEADED 92 10% ETH LAC	+0.0858	3.2940

OR UMATILLA-TWB/RF Effective: 03/02/2026 18:00

Product-Branded	Change	Price	Product-Branded	Change	Price
ULSD15 #1 CLEAR	+0.1451	4.0008	ULSD15 #1 DYED	+0.1451	4.0048
ULSD15 #2 CLEAR B5	+0.1403	3.3042	ULSD15 #2 CLEAR B20	+0.1403	3.3042
ULSD15 #2 DYED B5	+0.1404	3.3083	ULSD15 #2 DYED B20	+0.1404	3.3083

WA SEATTLE-BP/RF Effective: 03/02/2026 18:00

Product-Branded	Change	Price	Product-Branded	Change	Price
ULSD15 #1 CLEAR	+0.1386	4.2601	ULSD15 #1 DYED	+0.1387	4.2642
ULSD15 #2 CLEAR	+0.1387	3.7046	ULSD15 #2 DYED	+0.1386	3.7086
ULSD15 #2 CLEAR B20	+0.1312	4.0430	UNLEADED 92 10% ETH	+0.1012	3.4436
ULSD15 #2 DYED B20	+0.1312	4.0471	UNLEADED 87 10% ETH	+0.0892	3.0916
UNLEADED 87 BLEND CLEAR	+0.0897	3.4127	UNLEADED 89 3-WAY 10% ETH	+0.1021	3.3052

WA TACOMA-PAR/RF/PR Effective: 03/02/2026 18:00

Product-Branded	Change	Price	Product-Branded	Change	Price
ULSD15 #2 CLEAR	+0.1394	3.7656	ULSD15 #2 DYED	+0.1394	3.7697
CENEX® ROADMASTER XL	+0.1394	3.8131	CENEX® RUBY FIELDMASTER	+0.1394	3.8171
UNLEADED PREMIUM BLEND GRADE 10% ETH	+0.0838	3.4818	UNLEADED 89	+0.0981	3.7876
UNLEADED 92	+0.1058	4.4737	UNLEADED 87 10% ETH	+0.0982	3.0877
UNLEADED 87 BLEND CLEAR	+0.0981	3.7671	UNLEADED 89 3-WAY 10% ETH	+0.0837	3.3291

**CITY OF GRANDVIEW
AGENDA ITEM HISTORY/COMMENTARY
COMMITTEE-OF-THE-WHOLE MEETING**

ITEM TITLE:

Resolution accepting a request from Hugo Garibay for annexation of Parcel Nos. 230927-11424 and 230927-11425 located at 160 Hickory Road, Grandview, Yakima, County, Washington to the City of Grandview

AGENDA NO. New Business 3 (F)

AGENDA DATE: March 10, 2026

DEPARTMENT

Planning

FUNDING CERTIFICATION (City Treasurer)
(If applicable)

DEPARTMENT DIRECTOR REVIEW

Anita Palacios, City Clerk (Planning)

CITY ADMINISTRATOR



MAYOR

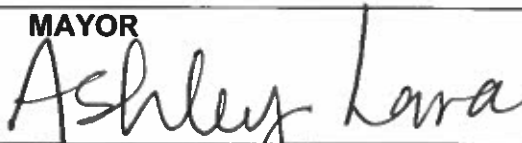

ITEM HISTORY (Previous council reviews, action related to this item, and other pertinent history)

N/A

ITEM COMMENTARY (Background, discussion, key points, recommendations, etc.) Please identify any or all impacts this proposed action would have on the City budget, personnel resources, and/or residents.

The City received a Letter of Intent and Petition for Annexation and Rezone signed by Hugo Garibay to annex the following parcels located at 160 Hickory Road, Grandview, Yakima County, Washington, to the City of Grandview:

Parcel No.	Property Owner	Address	Assessed Value	60%
230927-11424	Hugo Garibay	160 Hickory Road	\$145,500	\$145,500
230927-11425	Hugo Garibay	160 Hickory Road	\$87,800	\$87,800
			\$233,300	\$233,300

The petitioner elected to request annexation under the 60% petition method of annexation. The 60% petition method requires signatures by owners of not less than 60% of the assessed value of the total property proposed for annexation. The petition does contain sufficient signatures of the assessed value.

The petitioner requested the parcels be annexed with an R-2 Medium Density Residential zoning designation. The two parcels are included in the City's designated Urban Growth Area with a future land use of Residential.

State law requires the City Council to determine: (1) if the City will accept, modify or reject the proposed annexation, (2) whether the City will require the simultaneous adoption of a proposed zoning regulation for the subject property, and (3) whether the City will require the assumption of all or any portion of existing City indebtedness by the area to be annexed.

Upon acceptance of the Letter of Intent, the Petition will be presented to the Hearing Examiner to conduct a public hearing.

ACTION PROPOSED

Move a resolution accepting a request from Hugo Garibay for annexation of Parcel Nos. 230927-11424 and 230927-11425 located at 160 Hickory Road, Grandview, Yakima, County, Washington to the City of Grandview to the March 10, 2026 regular Council meeting for consideration.

LETTER OF INTENTION (60% PETITION METHOD) TO COMMENCE ANNEXATION PROCEEDINGS TO THE CITY OF GRANDVIEW, WASHINGTON

TO: The City Council
City of Grandview
Grandview, Washington

We, the undersigned, owners of property representing not less than 10% of the assessed value of the property for which annexation is sought, described herein below, lying contiguous to the City of Grandview, Washington do hereby notify the City Council of the City of Grandview of our intention to seek annexation to and be made a part of the City of Grandview under the provisions of R.C.W. 35A.14.120, et seq., and any amendments thereto, of the State of Washington.

The territory proposed to be annexed is within Yakima County, Washington, and is legally described as follows: (Attach map outlining the boundaries of the property sought to be annexed).

See Attached

We are requesting City Council consideration of our request and are asking that the above property as R2 zone.

OWNER'S SIGNATURE: *[Signature]* DATE: 3/4/2026

OWNER'S SIGNATURE: _____ DATE: _____

PRINTED NAME: Hugo E Garibay

MAILING ADDRESS: 708 N. 5th Street Grandview, WA 98930

TELEPHONE NO.: (509) 380-2997

PARCEL NO.: 23092711425, 23092711424

PROPERTY LEGAL DESCRIPTION:
See Attached

60% PETITION METHOD FOR ANNEXATION
TO THE CITY OF GRANDVIEW, WASHINGTON

TO: The City Council
City of Grandview
Grandview, Washington

We, the undersigned, being owners of not less than 60% of the assessed value of the property for which annexation is petitioned lying contiguous to the City of Grandview, Washington do hereby petition that such territory be annexed to and made a part of the City of Grandview under the provisions of RCW 35A.14.120 and any amendments thereto, of the State of Washington.

The territory proposed to be annexed is within Yakima County, Washington, and is legally described as follows: (Attach map outlining the boundaries of the property sought to be annexed).

See Attached

WHEREFORE, the undersigned respectively petition the Honorable City Council and ask:

A. That appropriate action be taken to entertain this petition, fixing a date for public hearing, causing notice to be published and posted, specifying the time and place of such hearing and inviting all persons interested to appear and voice approval or disapproval of such annexation; and

B. That following such hearing, and subsequent to approval of the Yakima County Boundary Review Board if such is convened, the City Council determine by Ordinance that such annexation shall be effective; and that property to be annexed shall become part of the City of Grandview, Washington, subject to its laws and ordinances then and after in force.

The Petitioners subscribing hereto agree ". . . that all property within the territory hereby sought to be annexed shall be assessed and taxed at the same rate and on the same basis as property within the City of Grandview for any now outstanding

indebtedness of said City, including assessments or taxes in payment of any bonds issued or debts contracted, prior to or existing at the date of annexation, and that simultaneous adoption of proposed zoning regulations be required" in accordance with the requirements of the City Council of said City, and as quoted herein from the minute entry of the records of said City Council meeting. It is further understood that the zoning of said area proposed for annexation as shown in the Comprehensive Plan as adopted is R2 Residential.

This petition is accompanied and has attached hereto as Exhibit "A", a diagram which outlines the boundaries of the property sought to be annexed.

PRAYER OF PETITION:

1. Annexation of area described herein and on Exhibit "A";
2. Assumption of indebtedness of the City of Grandview; and
3. Zoning of R2, consistent with the City of Grandview Comprehensive Plan.

WARNING: Every person who signs this petition with any other than his/her true name, or who knowingly signs a petition when he/she is otherwise not qualified to sign, or who makes any false statements, shall be guilty of a misdemeanor.

OWNER'S SIGNATURE: [Signature] DATE: 3/4/2026

OWNER'S SIGNATURE: _____ DATE: _____

PRINTED NAME: Hugo E Faribay

MAILING ADDRESS: 708 N. 5th Street Grandview WA 98930

TELEPHONE NO: (509) 380-2997

PARCEL NO.: 23092711424, 23092711425

PROPERTY LEGAL DESCRIPTION:
See Attached

Yakima County - Land Information Portal

Exhibit "A"

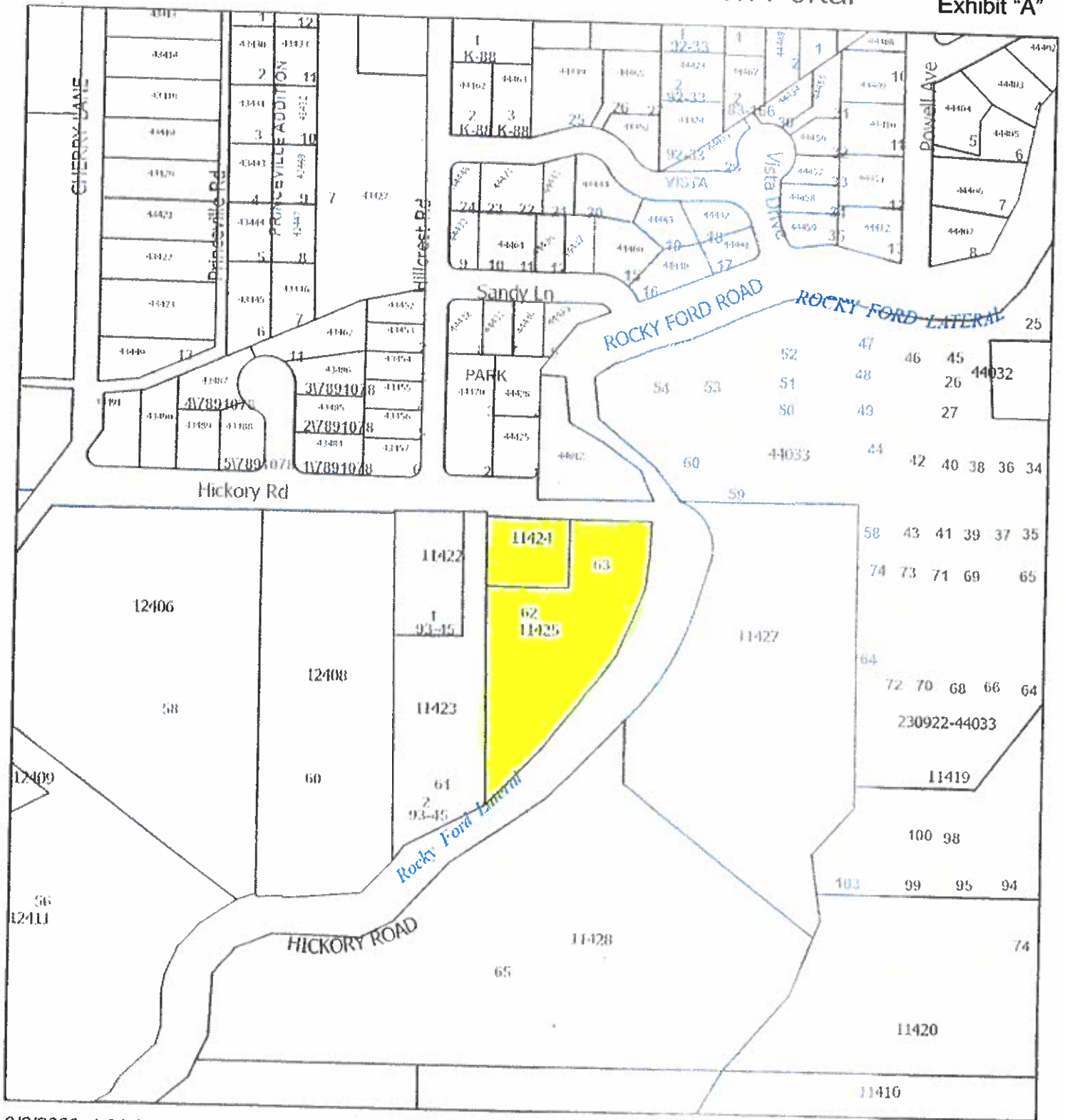



Aviation

Planning

County Roads

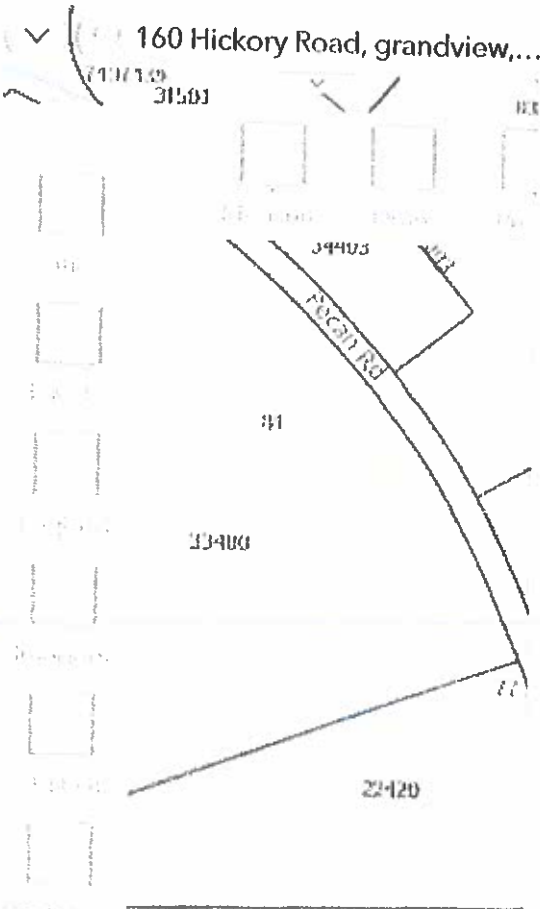

230927-11424

Zoom to

PROPERTY INFORMATION			
Parcel Owner(s):	HUGO GARIBAY		
Parcel Address:	160 HICKORY RD. GRANDVIEW, WA 98930		
Parcel Number:	23092711424	Parcel Size:	0.39 Acre(s)
Property Use:	11 Single Unit (Neighborhood: GV)		
TAX AND ASSESSMENT INFORMATION			
Tax Year:	2026	Tax Code Area:	TCA: 441
Land Value:	\$80,700	Improvement Value:	\$64,800
Current Use Value:	\$	CU Improvement:	\$
New Construction:	\$	Total Assessed Value:	\$145,500

230927-11424
3/8/07 #64

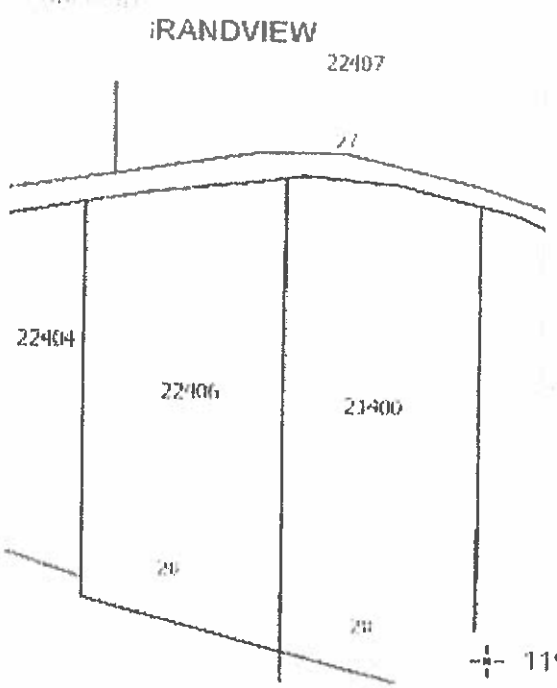
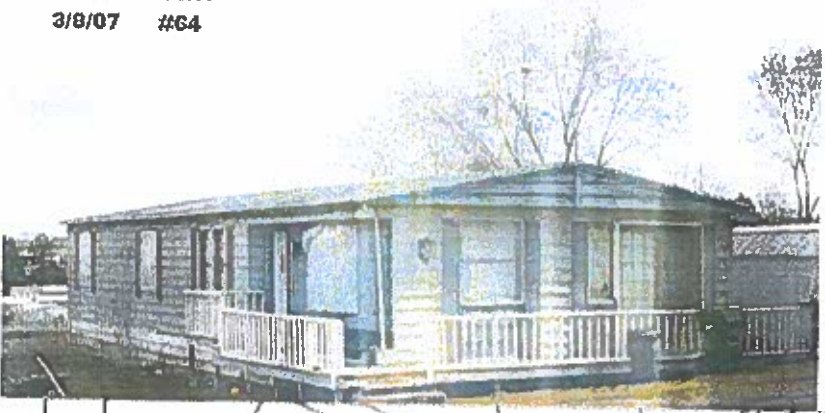



Assessor

Planning

County Roads

160 Hickory Road, grandview,...

Click on Parcel to Get

230927-11425

Zoom to

PROPERTY INFORMATION			
Parcel Owner(s):	HUGO GARIBAY		
Parcel Address:	160 HICKORY RD. GRANDVIEW, WA 98930		
Parcel Number:	23092711425	Parcel Area:	1.77 Acre(s)
Property Use:	91 Undeveloped Land (Neighborhood: GV)		
TAX AND ASSESSMENT INFORMATION			
Tax Year:	2026	Exc Code Area:	TCA: 441
Land Value:	\$87,800	Improvement Value:	\$0
Current Use Value:	\$	CU Improvement:	\$
New Construction:	\$	Total Assessed Value:	\$87,800

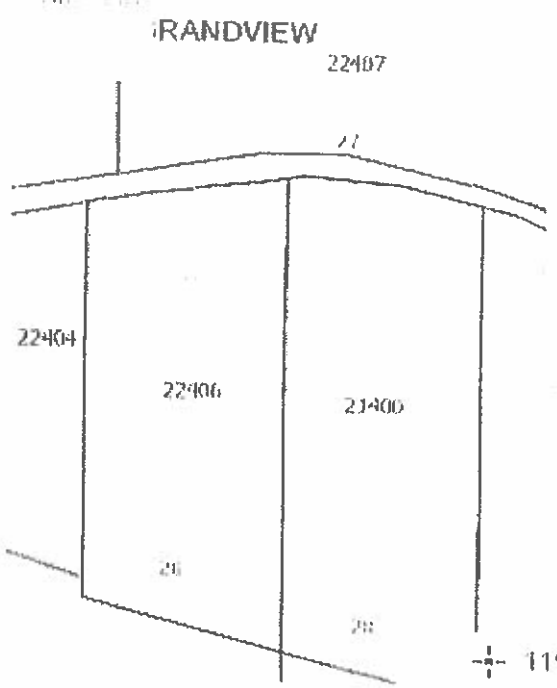
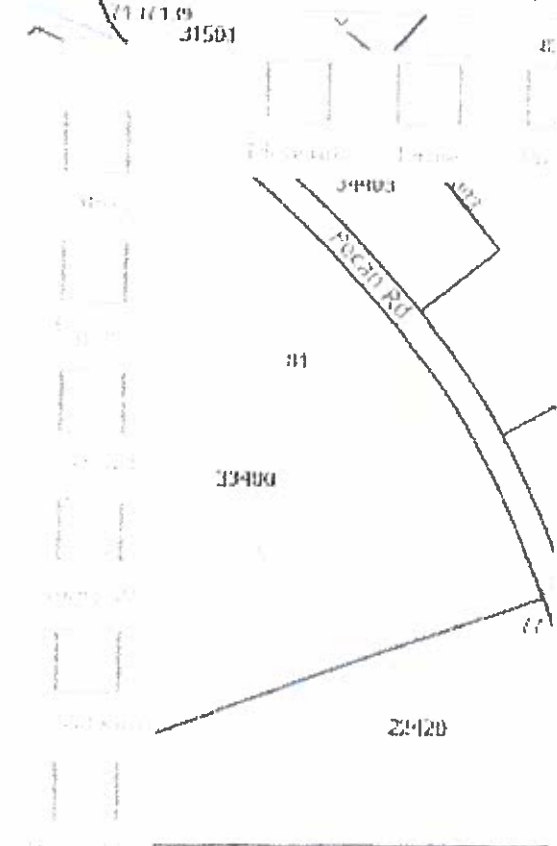

200 ft

MAP AND PARCEL DATA ARE BELIEVED TO BE ACCURATE, BUT ACCURACY IS NOT GUARANTEED; THIS IS NOT A LEGAL DOCUMENT AND SHOULD NOT BE SUBSTITUTED FOR A TITLE SEARCH. ADDITIONAL CLARIFICATION IS AVAILABLE AT

Powered by Esri

RESOLUTION NO. 2026-_____

**A RESOLUTION OF THE CITY OF GRANDVIEW, WASHINGTON,
ACCEPTING A REQUEST FROM HUGO GARIBAY FOR ANNEXATION OF PARCEL
NOS. 230927-11424 AND 230927-11425 LOCATED AT 160 HICKORY ROAD,
GRANDVIEW, YAKIMA COUNTY, WASHINGTON TO THE CITY OF GRANDVIEW**

WHEREAS, Hugo Garibay submitted a Letter of Intent to the City requesting annexation of Parcel Nos. 230927-11424 and 230927-11425 located at 160 Hickory Road, Grandview, Yakima County, Washington to the City of Grandview; and

WHEREAS, on March 10, 2026, the City Council was presented with the Letter of Intent and Petition for Annexation and reviewed the proposed annexation,

NOW, THEREFORE, BE IT RESOLVED BY THE CITY COUNCIL OF THE CITY OF GRANDVIEW, AS FOLLOWS:

Section 1. The City of Grandview hereby accepts the request for annexation subject to the following conditions:

- That the annexation be accepted as proposed on Exhibit "A" attached hereto.
- That the City requires the simultaneous adoption of the City's zoning regulations consistent with the Urban Growth Area Future Land Use Designation: R-2 Medium Density Residential for the proposed annexation.
- That the City requires the assumption of an appropriate share of all existing City indebtedness by the area to be annexed.

Section 2. Staff is hereby directed to present the Petition for Annexation to the Hearing Examiner who shall receive and examine available information, conduct a public hearing, prepare a record thereof and enter findings of fact and conclusions based upon those facts, together with a recommendation to the City Council.

PASSED by the **CITY COUNCIL** and **APPROVED** by the **MAYOR** at its regular meeting on _____, 2026.

MAYOR

ATTEST:

CITY CLERK

APPROVED AS TO FORM:

CITY ATTORNEY

Yakima County - Land Information Portal

Exhibit "A"

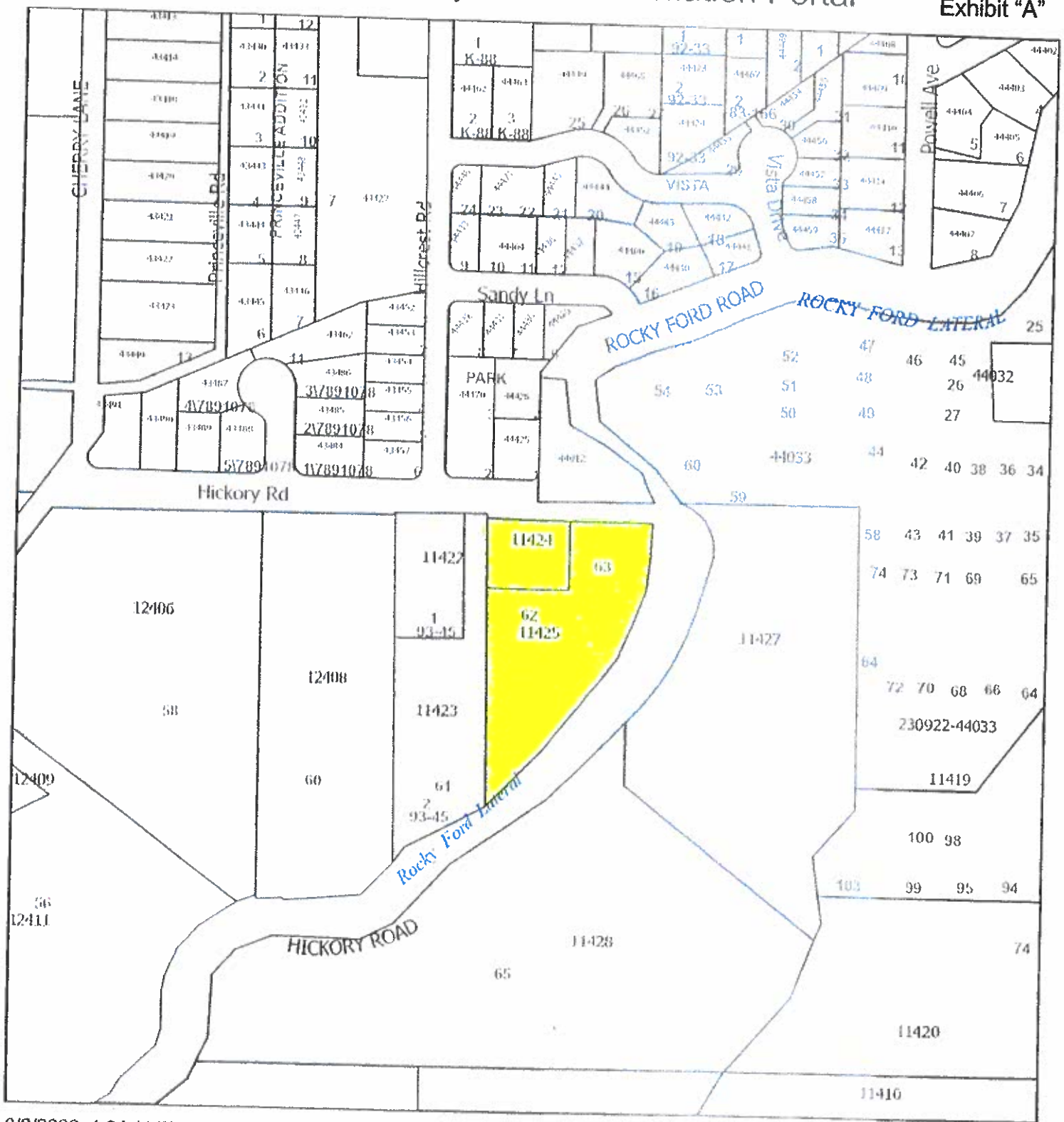

3/2/2026, 1:34:11 PM

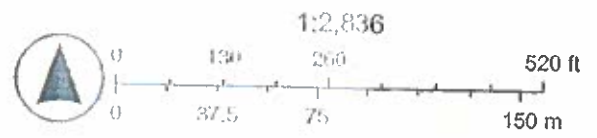

Copyright: Esri, DeLorme, Garmin, FMG, NOAA, USGS, © OpenStreetMap contributors, and the GIS User Community, Sources: Esri, Vantor, Orb
IMAGE, NOAA, NASA, CGMAI, N. Robinson, NCEAS, NLS, S. NMA
© Esri/DeLorme, Topographical, GSA, Fieoland, FEMA, Interm, and the
GIS User Community.

47
Yakima County GIS



Washington

Planning

County Roads

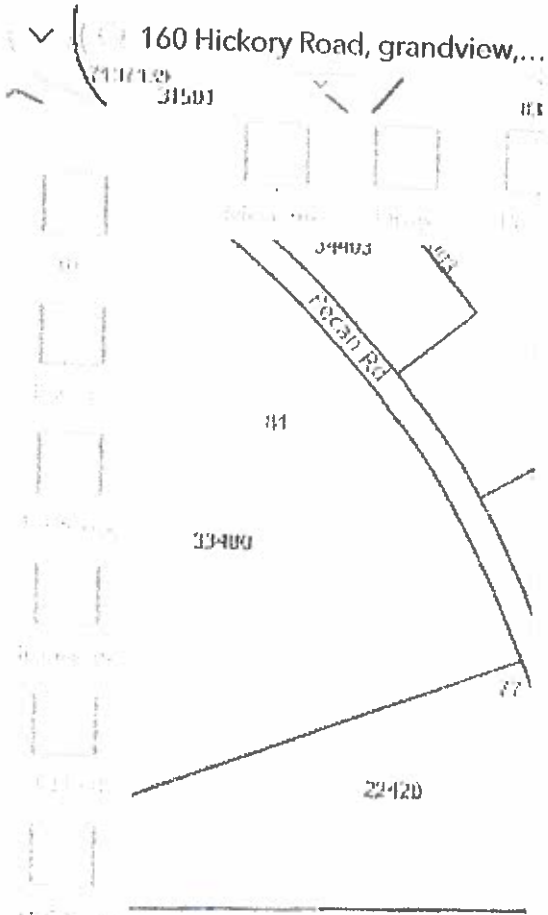

Click on Parcel to Get...

230927-11424

1 of 2
434

Zoom to

PROPERTY INFORMATION			
Parcel Owner(s):	HUGO GARIBAY		
Parcel Address:	160 HICKORY RD, GRANDVIEW, WA 98930		
Parcel Number:	23092711424	Parcel Size:	0.39 Acre(s)
Property Use:	11 Single Unit (Neighborhood: GV)		
TAX AND ASSESSMENT INFORMATION			
Tax Year:	2026	Tax Code Area:	TCA: 441
Land Value:	\$80,700	Improvement Value:	\$64,800
Current Use Value:	\$	CU Improvement:	\$
New Construction:	\$	Total Assessed Value:	\$145,500

230927-11424
3/8/07 #64

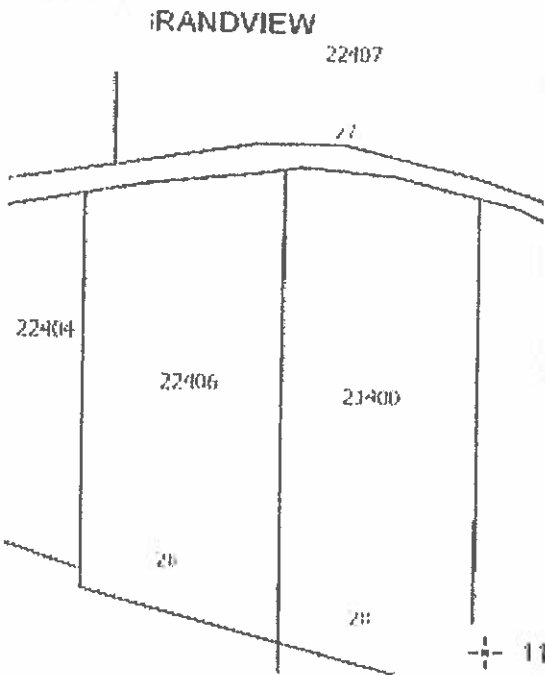
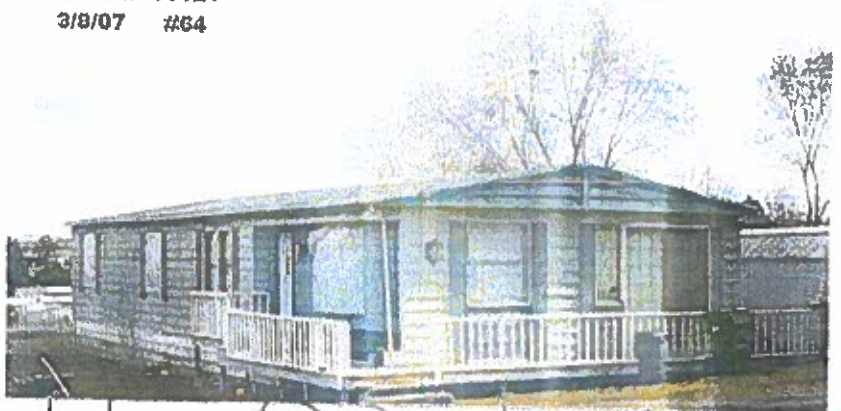

119°55'13.442"W 46°14'34.021"N

200 ft

Powered by Esri

MAP AND PARCEL DATA ARE BELIEVED TO BE ACCURATE, BUT ACCURACY IS NOT GUARANTEED; THIS IS NOT A LEGAL DOCUMENT AND SHOULD NOT BE SUBSTITUTED FOR A TITLE SEARCH. ADDITIONAL GUIDANCE IS AVAILABLE AT <https://www.esri.com/en-us/arcgis/products/arcgis-online/faq/accuracy>



Assessor

Planning

County Roads

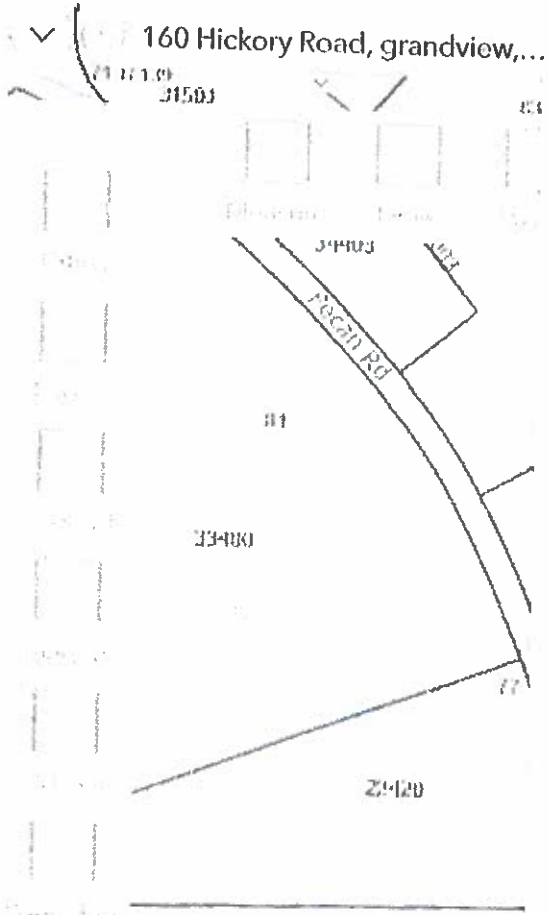

Click on Parcel to Get
230927-11425

Zoom to

PROPERTY INFORMATION	
Parcel Owner(s):	HUGO GARIJAY
Parcel Address:	160 HICKORY RD. GRANDVIEW, WA 98930
Parcel Number:	23092711425 Parcel Size: 1.77 Acre(s)
Property Use:	91 Undeveloped Land (Neighborhood: GV)
TAX AND ASSESSMENT INFORMATION	
Tax Year:	2026 Tax Code Area: TCA: 441
Land Value:	\$87,800 Improvement Value: \$0
Current Use Value:	\$ CUI Improvement: \$
New Construction:	\$ Total Assessed Value: \$87,800
Parcel Images	

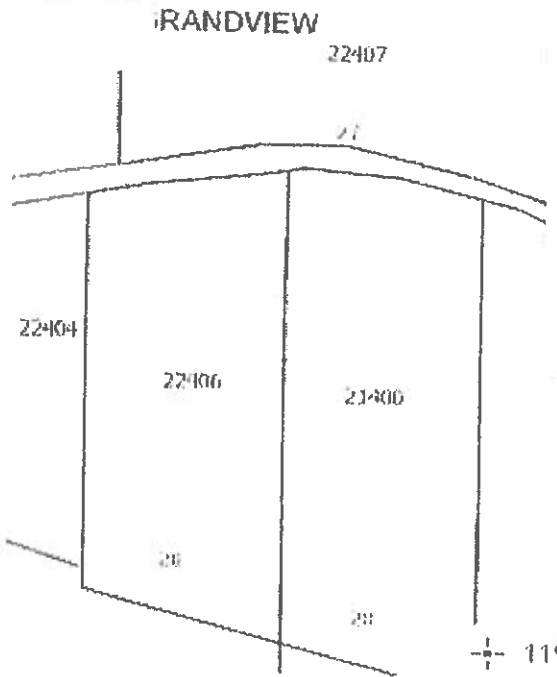

119°55'09.847"W 46°14'34.586"N

200 ft

MAP AND PARCEL DATA ARE BELIEVED TO BE ACCURATE, BUT ACCURACY IS NOT GUARANTEED; THIS IS NOT A LEGAL DOCUMENT AND SHOULD NOT BE SUBSTITUTED FOR A TITLE SEARCH. APPROPRIATE DISCLOSURES APPLY.

Powered by Esri